

## **3700 Series**

---

Flat-Panel Industrial PCs

User Manual for the  
3712KPM, 3712KPMT,  
3715T, 3715KPM, & 3715KPMT  
Models

<b>Revision</b>	<b>Description</b>	<b>Date</b>
A	Manual Released	01/04
B	Added 3712 series information, keypad inserts, updated <i>kp3util</i>	03/04
C	Updated touch screen driver installation and calibration / Added TIR caution	05/04 06/04
D	Clarified front panel frame, glass and overlay in Tables 1-1 & 1-2	08/04
E	Updated 3712KPM(T) available power specifications/ Added 24V DC power supply information	09/04
F	RAID-Enabled Appendix added	10/04
G	Added System Battery Replacement section	01/06
H	Name change, correct where applicable with document	4/07

## Part Number 143311 (H)

### Trademark Information

Xycom and Xycom Automation are trademarks of Xycom Automation, L.L.C.

Xycom Automation, L.L.C. now is referred to as Pro-face through a D.B.A. The Pro-face name and logo will replace the Xycom name and logo on all documents where possible.

Pro-face is a trademark of Digital Electronics Corporation.

Brand or product names are trademarks or registered trademarks of their respective owners.

Intel and Pentium are registered trademarks and Celeron is a trademark of Intel Corporation.

Windows, Windows NT, and Windows XP are registered trademarks of Microsoft Corporation in the U.S. and in other countries.

### Copyright Information

This document is copyrighted by Xycom Automation, L.L.C. (Xycom) and shall not be reproduced or copied without expressed written authorization from Xycom Automation, L.L.C.

The information contained within this document is subject to change without notice. Pro-face does not guarantee the accuracy of the information

### United States FCC Part 15, Subpart B, Class A EMI Compliance Statement:

**NOTE:** This equipment has been tested and found to comply with the limits for a Class A digital device, pursuant to part 15 of the FCC Rules. These limits are designed to provide reasonable protection against harmful interference when the equipment is operated in a commercial environment. This equipment generates, uses, and can radiate radio frequency energy and, if not installed and used in accordance with the instruction manual, may cause harmful interference to radio communications. Operation of this equipment in a residential area is likely to cause harmful interference in which case the user will be required to correct the interference at the user's expense.

### For European Users – WARNING:

This is a Class A product. In a domestic environment this product may cause radio interference in which case the user may be required to take adequate measures.

### INSTALLATION – Electromagnetic Compatibility WARNING:

The connection of non-shielded equipment interface cables to this equipment will invalidate FCC EMI and European Union EMC compliance and may result in electromagnetic interference and/or susceptibility levels which are in violation of regulations applying to the legal operation of this device. It is the responsibility of the system integrator and/or user to apply the following directions relating to installation and configuration:

All interface cables must include shielded cables. Braid/foil type shields are recommended. Communication cable connectors must be metal, ideally zinc die-cast backshell types, and provide 360-degree protection about the interface wires. The cable shield braid must be terminated directly to the metal connector shell; ground drain wires alone are not adequate.

Protective measures for power and interface cables as described within this manual must be applied. Do not leave cables connected to unused interfaces or disconnected at one end. Changes or modifications to this device not expressly approved by the manufacturer could void the user's authority to operate the equipment.

EMC compliance is, in part, a function of PCB design. Third party add-on AT/XT peripheral PCB assemblies installed within this apparatus may void EMC compliance. FCC/CE compliant PCB assemblies should always be used where possible. Pro-face can accept no responsibility for the EMC performance of this apparatus after system integrator/user installation of PCB assemblies not manufactured and/or expressly tested and approved for compliance by Pro-face. It is the responsibility of the system integrator/user to ensure that installation and operation of such devices does not void EMC compliance.

# Table of Contents

<b>CHAPTER 1 – INTRODUCTION .....</b>	<b>1</b>
PRODUCT OVERVIEW .....	1
STANDARD FEATURES .....	1
<i>Front Panels</i> .....	3
<i>I/O Panel</i> .....	7
<i>Back Panel</i> .....	9
<i>Power Panel</i> .....	10
UNPACKING THE SYSTEM.....	11
QUICK STARTUP .....	11
<b>CHAPTER 2 – INSTALLATION.....</b>	<b>12</b>
INSTALLATION OVERVIEW .....	12
SYSTEM CUTOUT DIMENSIONS.....	14
3712kpm(t).....	14
3715T & 3715kPM(T).....	15
POWER MANAGEMENT.....	16
<i>System Power</i> .....	16
<i>Excessive Heat</i> .....	17
<i>Electrical Noise</i> .....	17
<i>Line Voltage Variation</i> .....	18
<i>AC Power Cable</i> .....	18
INSTALLING INTERNAL HARDWARE OPTIONS .....	19
<i>DRAM and Additional DRAM Dual Inline Memory Modules (DIMMs)</i> .....	20
<i>PC/AT™ and PCI Boards</i> .....	20
USING A TOUCH SCREEN .....	20
<i>Installing the Touch Screen Driver</i> .....	21
<i>Calibrating the Touch Screen</i> .....	22
CUSTOM LOGO .....	23
CREATING CUSTOM KEYPAD INSERTS .....	23
HAZARDOUS LOCATIONS INSTALLATION .....	29
<i>Safety Agency Approval</i> .....	29
<i>Definitions</i> .....	31
<i>Class I Locations</i> .....	31
<i>Class II Locations</i> .....	31
<i>Division 1 Locations</i> .....	31
<i>Division 2 Locations</i> .....	31
<i>Groups</i> .....	32
<i>Enclosures</i> .....	32
<i>Power Switch</i> .....	33
<i>Cable Connections</i> .....	33
<i>Communication Cable Interfaces</i> .....	33
<i>Hazardous Locations Control Drawing</i> .....	34
<i>Operation and Maintenance</i> .....	35
<b>CHAPTER 3 – KEYPAD UTILITY PROGRAM.....</b>	<b>36</b>
LOADING THE KEYPAD UTILITY.....	36
USING THE KEYPAD UTILITY .....	36
STARTUP .....	37
MAIN MENU.....	37
<i>Exit</i> .....	38
<i>Files Menu</i> .....	38
<i>Macros Menu</i> .....	39
<i>Upload Menu</i> .....	41
<i>Download Menu</i> .....	41
<i>Utilities Menu</i> .....	42
UTILITY BATCH MODE.....	42
KEYPAD SCAN CODES .....	43

<b>CHAPTER 4 – MAINTENANCE .....</b>	<b>46</b>
GENERAL PREVENTIVE MAINTENANCE.....	46
<i>Fuse Replacement</i> .....	46
<i>Fan Filter Replacement</i> .....	47
RECOMMENDED HARD DRIVE PREVENTIVE MAINTENANCE.....	47
SYSTEM BATTERY REPLACEMENT .....	48
PRODUCT REPAIR PROGRAM.....	51
3700 FRONT PANEL FRAME.....	53
<i>Chemicals Compatible with 3700 Frame</i> .....	53
<i>Front Panel Overlay</i> .....	54
<i>Chemicals Compatible with Overlay</i> .....	54
<i>Compatible Cleaning Agents for Overlay</i> .....	54
<i>Chemicals Not Compatible with Overlay</i> .....	54
<b>CHAPTER 5 – TROUBLESHOOTING.....</b>	<b>55</b>
DIAGNOSTIC TESTING .....	55
<i>Create Diagnostic Disk</i> .....	55
<i>Prepare the System</i> .....	55
RUNNING THE TESTS .....	57
REINSTALLING OPERATING SYSTEMS .....	58
<i>MS-DOS® Reinstallation</i> .....	58
<i>Windows® 98 Reinstallation</i> .....	58
<i>Windows® 2000 Reinstallation</i> .....	59
<i>Windows NT® Reinstallation</i> .....	59
<i>Windows XP® Reinstallation</i> .....	59
INSTALLING DRIVERS .....	60
<i>Video Drivers</i> .....	60
<i>Video Expansion</i> .....	60
<i>Touch Screen Drivers</i> .....	61
<i>Miscellaneous Drivers</i> .....	61
<b>APPENDIX A – TECHNICAL SPECIFICATIONS.....</b>	<b>62</b>
HARDWARE SPECIFICATIONS.....	62
ENVIRONMENTAL SPECIFICATIONS .....	63
<b>APPENDIX B – BLOCK DIAGRAM AND AIM3 LAYOUT.....</b>	<b>64</b>
AC MODEL BLOCK DIAGRAM.....	64
AIM3 CPU BOARD LAYOUT.....	65
<b>APPENDIX C – PINOUTS .....</b>	<b>66</b>
KEYBOARD PORT CONNECTOR .....	66
MOUSE PORT CONNECTOR .....	66
DUAL USB CONNECTOR (USB1).....	67
PARALLEL PORT CONNECTOR (LPT1).....	67
SERIAL PORT CONNECTORS.....	68
COM1.....	68
COM2.....	69
VGA CONNECTOR .....	69
<b>APPENDIX D – AIM3 CONTROLLER JUMPERS.....</b>	<b>70</b>
<b>APPENDIX E – TSKAM SETTINGS.....</b>	<b>71</b>
<b>APPENDIX F – THE RAID-ENABLED IPC OPTION.....</b>	<b>72</b>

# Chapter 1 – Introduction

---

## Product Overview

The 3700 series of Flat Panel Industrial Computers combines an Intel® Celeron® or Pentium® III processor with a flat-panel display to offer a powerful, compact package for the factory floor and other harsh environments. The PC features an open architecture to meet a wide variety of applications that require both a powerful PC and a durable industrial enclosure. The system integrates a computer card cage, mass storage, display, and power supply in a reliable industrial form factor.

The 3715T is an industrial PC with touch screen display. The 3712KPM and 3715KPM are industrial PCs, which contain a display, an integrated keypad and an integrated mouse. The 3712KPMT and 3715KPMT are industrial PCs, which contain an integrated keypad, an integrated mouse, and a touch screen display.

The front panels of the 3700 units are sealed to NEMA TYPE 4/4X/12 (UL 50) and IP65 (IEC 60529) standards and are protected by an impact-resistant shield.

The processor board combines all the functions of a complete PC/AT compatible computer on a single industrially-hardened circuit board. Refer to the AIM3 CPU manual for more information on processor and hardware features.

The system's modular design allows easy access to expansion boards, switches, power supply, flat-panel display, and disk drives.

## Standard Features

The 3700 unit comes standard with the following:

- AIM3 CPU Board
  - Two serial COM ports, with one configured as RS-232 and one configurable as either RS-232 or RS-485
  - Parallel port
  - VGA port
  - Intel® Socket 370 Celeron® or Pentium® III options up to 1.26GHz
  - AGP video controller, 4 MB system video RAM, up to 32 MB available
  - PCI local-bus IDE controller
  - Two 168-pin SDRAM DIMM sites that support 128, & 256 MB DIMMs, for up to 512 MB total memory
  - Two USB 1.1 ports
  - 100MHz or 133MHz front side bus depending on the Celeron or Pentium III processor type

- Standard Features of a 3700 Unit
  - Flash BIOS
  - 6.42" mounting depth (maximum for all 3700 models)
  - Flat-panel active color TFT display:
    - 12.1" (800x600) on 3712s
    - 15" (1024x768) on 3715s
  - Four AT bus expansion slots
    - One ½ length PCI
    - One full-length ISA
    - One full-length PCI
    - One full-length PCI slot or ISA slot
  - Rear IBM® PS/2® keyboard port and mouse port on all units
  - Front PS/2® keyboard port and front USB port available on the 3712KPM(T) and 3715KPM(T) models
  - Status LEDs
    - Power
    - Disk
    - COM
    - Input
    - Fault
  - Floppy drive, rear access
  - CD-ROM, rear access
  - Removable 20 GB hard drive, rear access
  - 200 watt power supply
  - MS-DOS® operating system
  - All 3700 front panels meet NEMA 4/4X/12 and IP65 specifications when panel mounted
  - UL Listed for use in Class I and Class II, Division 2 Hazardous Locations, Groups A, B, C, D, F, and G
  - UL 508 Listed
- Additional standard features 3712KPM(T) & 3715KPM(T) models
  - 40 relegendable function keys (80 with the F/A function)
  - Numeric, PC control, and alpha keypads
  - Windows® start menu and pop-up menu keys
  - Integrated mouse
  - Nonincendive front panel USB and keyboard ports

The figures and tables on the next several pages illustrate the internal and external components on the front and back panels of the unit to help you locate the features of the 3700 series.

## Front Panels

Figure 1-1 shows the 3715T front panel, and Table 2-1 outlines the features of this model. Figure 1-2 shows the 3712KPM(T) and 3715KPM(T) front panel, and Table 1-2 outlines the features of these models.

### 3715T Front Panel

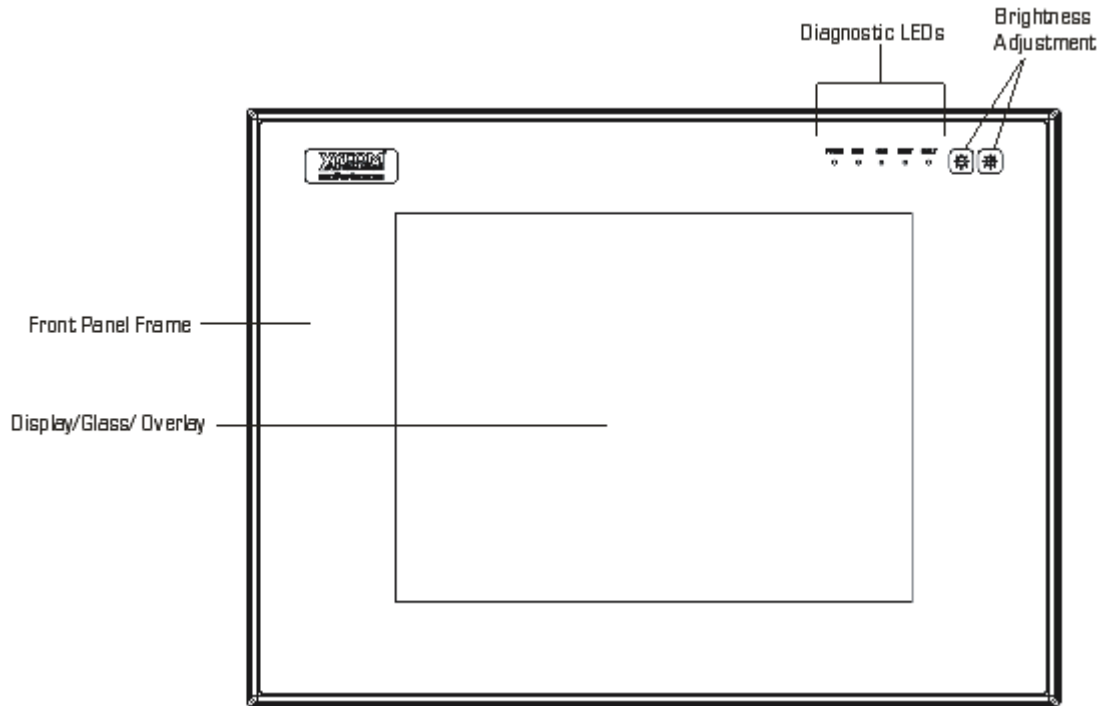

Figure 1-1. 3715T Front Panel

Table 1-1. 3715T Front Panel Features

Feature	Description
Display	<p>The front panel has four components: a display; strengthened glass covering the display; a frame in which the display and the glass are mounted; and the polyester overlay attached to both the glass and the frame.</p> <p>The 3715T has a 15" TFT LCD flat panel.</p> <p>The strengthened glass covering the display is intended to withstand normal operating conditions. In the event of damage to the glass, the overlay will protect the user from any glass shards.</p> <p>For more information about the frame or the overlay, see Chapter 4 – Maintenance.</p>
Diagnostic LEDs	<p>Following are descriptions of the LEDs and their meanings:</p> <p>Power    GREEN when the system has power.</p> <p>Disk      GREEN when the computer is accessing the disk drive.</p> <p>COM      GREEN when there is communication activity on one of the serial ports.</p> <p>Input     GREEN when the unit has a touch screen (LED gets brighter when a touch input is detected or a key is pressed.)</p> <p>Fault     YELLOW when a configuration error exists.</p> <p>During power-up, the BIOS checks the hardware configuration against the configuration stored in the CMOS memory.</p>
Brightness Control	<p>These buttons adjust the brightness of the backlights. The right button increases the brightness and the left button decreases the brightness.</p>

### 3712KPM(T) & 3715KPM(T) Front Panel

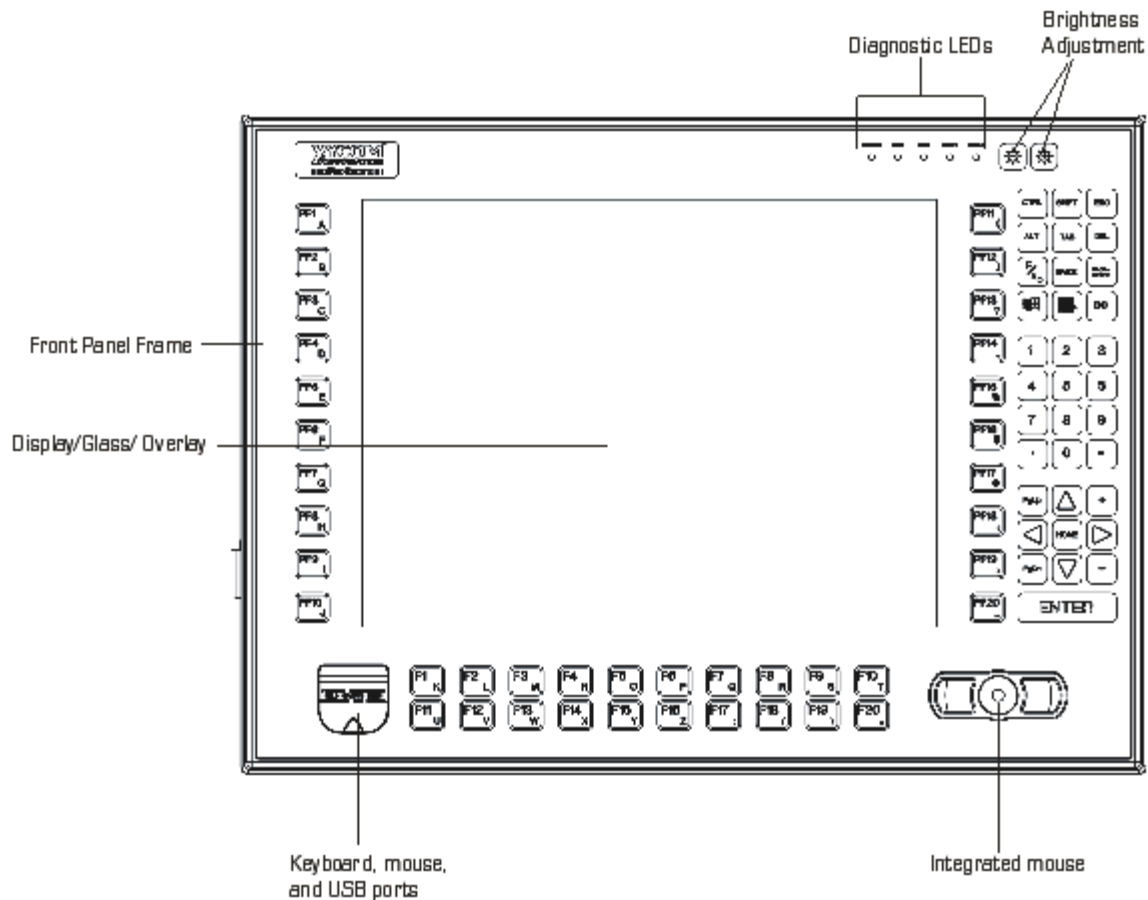

Figure 1-2. 3715KPM(T) Front Panel

The 3712KPM(T) and 3715KPM(T) feature function keys on either side of the flat panel display (PF1-PF20), function keys below the display (F1-F20), a numeric keypad, window keys, a cursor control keypad, diagnostic LEDs, an integrated mouse, industrial mouse/keyboard and USB ports. All keypad keys are reprogrammable<sup>1</sup>, except the F/A key, and all function keys are relegendable<sup>2</sup>. See Chapter 3 for more details.

<sup>1</sup> All keypad keys can be programmed to perform any function necessary.

<sup>2</sup> You are able to create your own, custom keypad inserts to reflect any reprogramming you may have done.

Table 1-2. 3712/15KPM(T) Front Panel Features

Feature	Description
Front Panel	<p>The front panel has four components: a display; strengthened glass covering the display; a frame in which the display and the glass are mounted; and the polyester overlay attached to both the glass and the frame.</p> <p>The 3712KPM(T) has a 12.1" TFT LCD flat panel. The 3715KPM(T) has a 15" TFT LCD flat panel.</p> <p>The strengthened glass covering the display is intended to withstand normal operating conditions. In the event of damage to the glass, the overlay will protect the user from any glass shards.</p> <p>For more information about the frame or the overlay, see Chapter 4 – Maintenance.</p>
Diagnostic LEDs	<p>Following is a description of the LEDs and their meanings:</p> <p>Power GREEN when the system has power.</p> <p>Disk GREEN when the computer is accessing the disk drive.</p> <p>COM GREEN when there is communication activity on one of the serial ports.</p> <p>Input GREEN when the unit has a touch screen (LED gets brighter when a touch input is detected) or a key is pressed.</p> <p>Fault YELLOW when a configuration error exists.</p> <p>During power-up, the BIOS checks the hardware configuration against the configuration stored in the CMOS memory.</p>
Brightness Control	<p>These buttons adjust the brightness of the backlights. The right button increases the brightness and the left button decreases the brightness.</p>
Port Access	<p>The 3712KPM(T) and 3715KPM(T) feature front panel access to a PS/2® keyboard/mouse port and a USB 1.1 port.</p> <p><b>These front access connections on the 3712KPM(T) and 3715KPM(T) are nonincendive circuits and may be used safely in Class I Division 2, Groups A, B, C, &amp; D and in Class II Division 2, Groups F &amp; G applications. Please reference the Hazardous Locations control drawing on page 34.</b></p>
74-Key Keypad	<p>The 3712KPM(T) and 3715KPM(T) keypads feature:</p> <ul style="list-style-type: none"> <li>• Alpha, numeric and control keys</li> <li>• 40 relegendable function keys</li> <li>• All keys reprogrammable</li> </ul>
Integrated Mouse	<p>The 3712KPM(T) &amp; 3715KPM(T) feature a 2-button integrated mouse.</p>

See Chapter 3, *Keypad Utility Program*, for detailed instructions on programming the keypad.

## I/O Panel

Figure 1-3 shows the 3700 System I/O panel, and Table 1-3 outlines the features of the I/O panel.

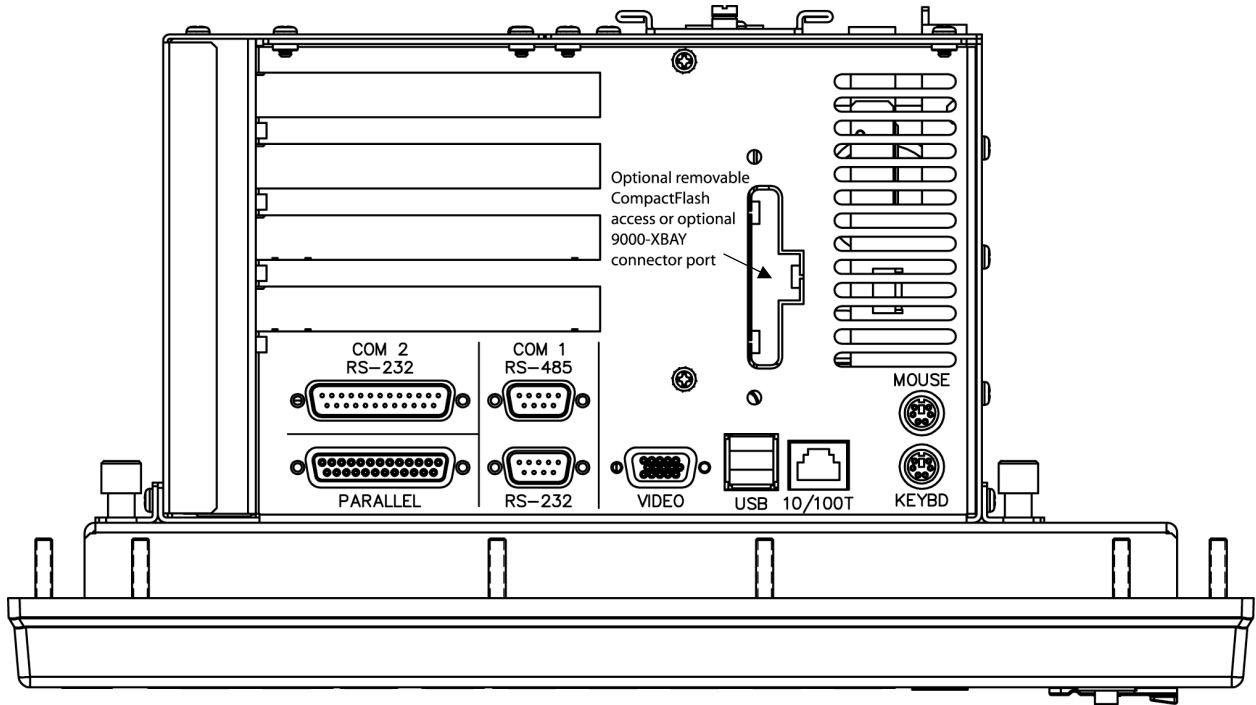

Figure 1-3. 3700 System I/O Panel

Table 1-3. 3700 System I/O Panel

Feature	Description
Parallel Port	The parallel printer port (LPT1) is a DB-25 female connector. This port provides a standard PC-compatible printer interface.
COM Ports	COM1 is RS-232/485 compatible. RS-232 is connected to the lower 9-pin stacked DB connector. The top part of this stack is the RS-485 version of the same port. Since these connectors are attached to the same port, only one can be used at a time. COM2 is the male 25-pin DB connector. An external push-button reset option and alarm feature is available. Consult the AIM3 CPU manual for the BIOS setting that controls this option.
Keyboard Port	The keyboard port is a PS/2 <sup>®</sup> stacked mini-DIN, so a PC/AT <sup>™</sup> keyboard can be attached at the side of the unit. The keyboard port on the side of the unit is the lower connector.  <b>Warning: To maintain a safe condition, do not use an external keyboard and/or mouse on these ports when the unit is operating in a hazardous environment.</b>
Mouse Port	The mouse port is a PS/2 <sup>®</sup> stacked mini-DIN that allows you to attach a mouse at the side of the unit. The mouse port is the upper connector.  <b>Warning: To maintain a safe condition, do not use an external keyboard and/or mouse on these ports when the unit is operating in a hazardous environment.</b>
Video Port	The video port is a 15-pin D-sub VGA connector on the side of the unit. This connector supports any standard VGA connection. Both the LCD flat panel and video port are active as a default at boot time if video display devices are connected to them.
USB	The Universal Serial Bus (USB) is a double-high connector on-board with a USB port to the off-board connector.
Ethernet Port	On-board 10/100BASET RJ-45 connector with LEDs.
Removable CompactFlash <sup>™</sup> access (optional)*	This option allows external access to Type I or Type II CompactFlash <sup>™</sup> for solid-state storage media.  <b>Note: This feature cannot be used if the removable CompactFlash<sup>™</sup> option was not ordered.</b>
9000-XBAY connector port (optional)*	The 9000-XBAY connector port is a factory-installed option that provides a connection from the 3700 to any two IDE devices used by the optional 9000-XBAY.  <b>Note: This feature cannot be used if the 9000-XBAY option was not ordered.</b>

\* This port can be used for the removable CompactFlash<sup>™</sup> or the external bay connector but *not* both. If the user chooses one of these options, it must be factory-installed.

## Back Panel

Figure 1-4 shows the 3700 System back panel.

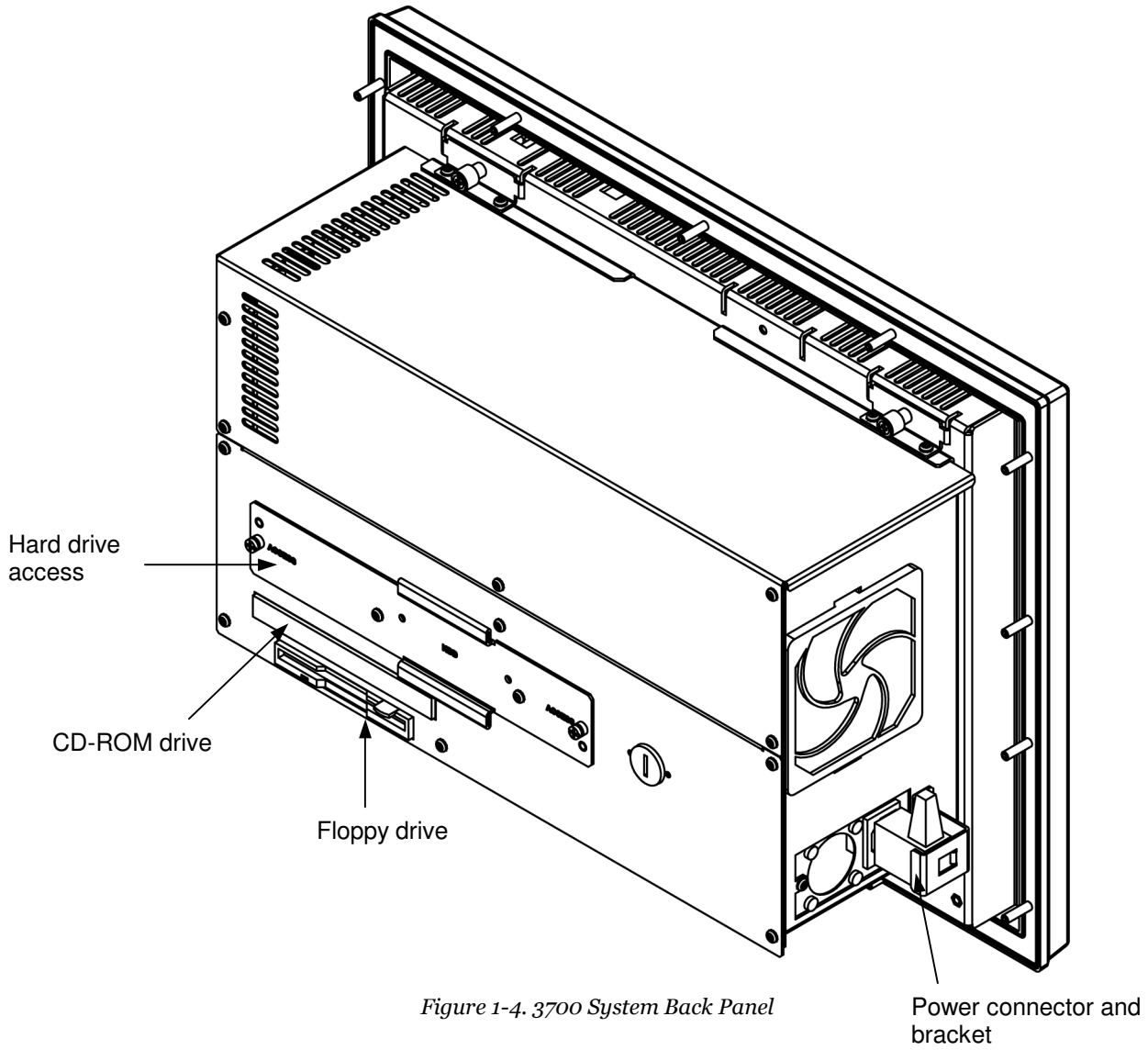

Figure 1-4. 3700 System Back Panel

## Power Panel

Figure 1-5 shows the 3700 System power panel, and Table 1-4 outlines the features of the power panel.

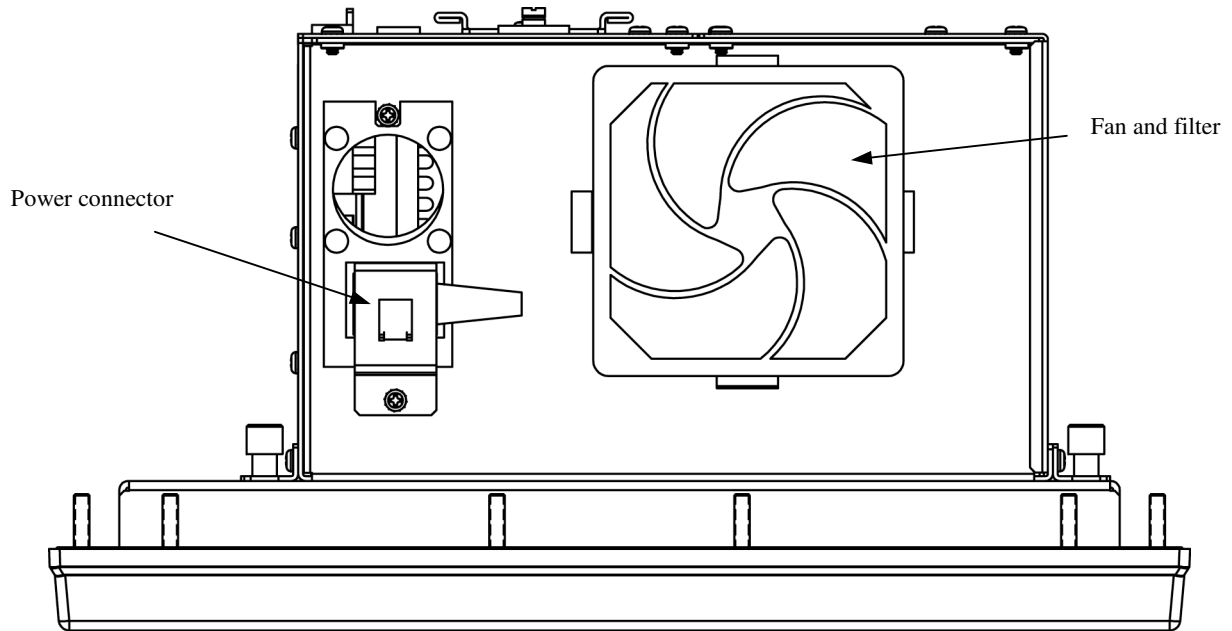

Figure 1-5. 3700 Side Panel with Fan Filter and Power Connector

Table 1-4. 3700 Power Panel Features

Feature	Description
Power Connector	This is a 3-pin connector. Refer to the special <i>Hazardous Locations Installation</i> instructions in Chapter 2.
Fan and Filter	The filter can be replaced or removed for cleaning. See Chapter 4 for details on the fan filter assembly.

## Unpacking the System

When you remove the system from its shipping container, verify that you have the parts listed below. Save the box and inner wrapping in the event you need to reship the unit.

- 3700 series computer
- Documentation kit, which includes:
  - Power connector
  - 10-32 hex nuts (for panel mounting with the studs)
  - Cable clamp and screw (for strain relief of power cord)
  - Documentation and Support Library CD-ROM
  - Operating System Recovery Media or operating system installation disk (CD-ROM)

## Quick Startup

This section gives you the steps to get the system up and running without explaining the capabilities and options.

### Warning

Remove power from the unit and disconnect the power cord before making any adjustments to the inside or outside of the computer.

### Warning

For Hazardous Locations installation, review “*Hazardous Locations Installation*” in Chapter 2 before startup.

To prepare the system for use, perform the following steps.

1. Attach optional keyboard to the keyboard port.
2. Attach optional mouse to the mouse port.
3. Attach other optional equipment following the instructions in Chapter 2.
4. Attach the power cord from the power receptacle to a properly grounded 115/230 VAC, 50-60 Hz outlet. (See Chapter 2, *AC Power Cable*.)
5. Turn on power to the unit (via an outlet power switch if applicable). The system will boot up into the operating system.
6. Install application software via the floppy, the CD-ROM, or the network, as applicable.

# Chapter 2 – Installation

---

This chapter offers detailed installation instructions and outlines the options for the 3700 series. It also includes the guidelines for preparing your 3700 unit for installation and use.

## Installation Overview

### Warning

For installation in Hazardous Locations, review the *Hazardous Locations Installation* section in this chapter before startup.

The rugged design of the 3700 unit allows it to be installed in most industrial environments. The system is generally placed in a NEMA 4/4X/12 enclosure to protect against contaminants such as dust, and moisture. Metal enclosures also help minimize the effects of electromagnetic radiation that nearby equipment can generate. For Underwriters Laboratories (UL) compliance, the unit must be installed within a suitable fire enclosure.

Read the following sections carefully to be sure that you are complying with all the safety requirements.

1. Select a NEMA rated enclosure and place the unit to allow easy access to the system ports (see other sections in this chapter and Appendix A).
  - To assure a NEMA 4 seal choose an approved enclosure that has a 14-gauge (0.075 in/1.9 mm thick steel or 0.125 in/3.2 mm thick aluminum) front face.
  - Be sure to account for the unit's depth when choosing the depth of the enclosure.
2. Create a cutout in the enclosure (see Figure 2-1 and Figure 2-2 in *System Cutout Dimensions*).
  - Be sure to place the unit at a comfortable working level
  - Make sure the area around the cutout is clean and free from metal burrs
3. Mount the unit in an upright position and properly secure the unit into the panel.
  - Tighten the fourteen #10 nuts to 25 inch-pounds (2.8 Newton-meters / 28Kgf cm).
4. Construct a power cable following the instructions in *AC Power Cable* in this chapter.

5. Attach one end of the power cord to the power receptacle on the unit and the other end to a properly grounded 115/230 VAC, 50-60 Hz outlet.
  - A ground path from the unit chassis to the enclosure chassis can be established using the 6-32 threaded ground point hole provided on the bottom panel of the unit
6. Turn on power to the system. The system will boot up the installed operating system.
7. Install the application software via a floppy drive, CD-ROM, or the network.

Additional aspects to take into account when mounting your 3700 unit:

- Consider locations of accessories such as AC power outlets and lighting (interior lighting and windows) for installation and maintenance convenience
- Prevent condensation by installing a thermostat-controlled heater or air conditioner
- To allow for maximum cooling, avoid obstructing the airflow
- Place any fans or blowers close to the heat generating devices. If using a fan, make sure that outside air is not brought into the enclosure unless a fabric or other reliable filter is used. This filtration prevents conductive particles and other harmful contaminants from entering the enclosure.
- Do not select a location near equipment that generates excessive electromagnetic interference (EMI) or radio frequency interface (RFI). Examples of these types of equipment are: high power welding machines; induction heating equipment; and large motor starters.
- Place incoming power line devices (such as isolation or constant voltage transformers, local power disconnects, and surge suppressers) away from the system. The proper location of incoming line devices keeps power wire runs as short as possible and minimizes electrical noise transmitted to the unit.
- Make sure the location does not exceed the unit's shock, vibration, and temperature specifications
- Install the unit in the rack or panel in such a way as to ensure that it does not cause a hazard from uneven mechanical loading
- Incorporate a readily-accessible disconnect device in the fixed wiring on permanently connected equipment
- Avoid circuit overloading of the supply circuit

## System Cutout Dimensions

Figure 2-1 shows the system cutout dimensions for the 3712KPM(T). Figure 2-2 shows the system cutout dimensions for the 3715KPM(T).

### 3712kpm(t)

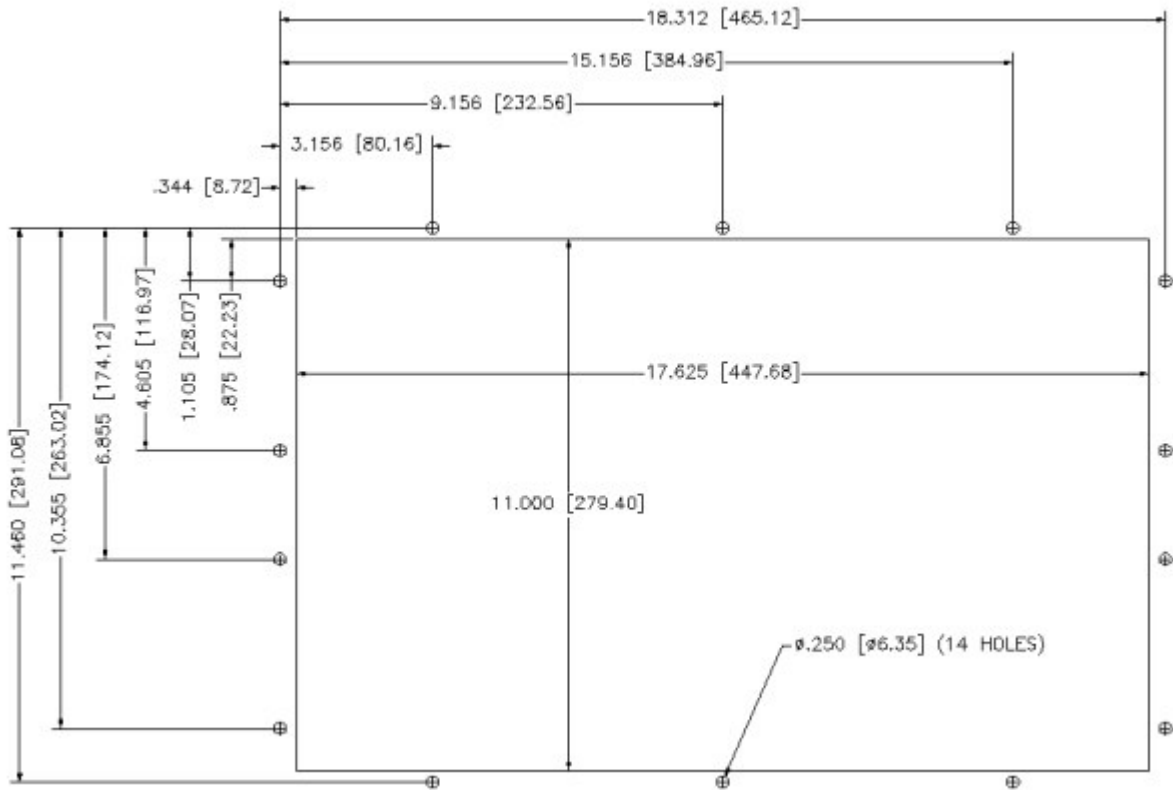

Figure 2-1. 3712KPM(T) System Cutout Dimensions (inches [mm])

### 3715T & 3715KPM(T)

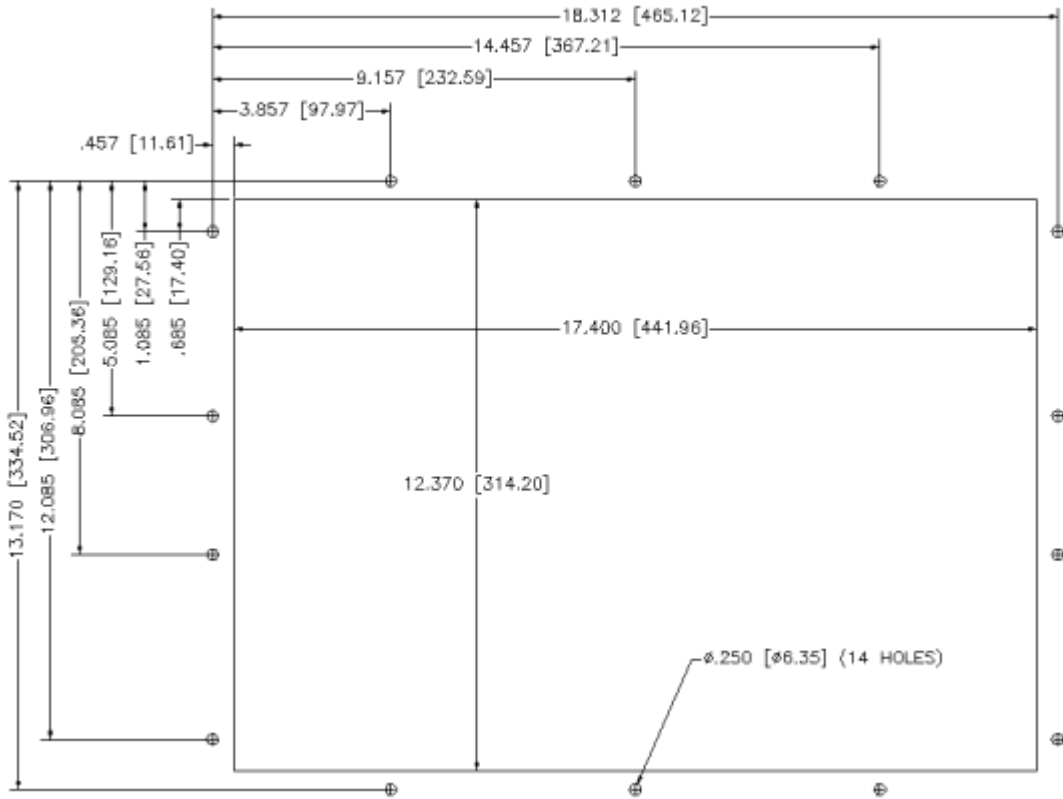

Figure 2-2. 3715T & 3715KPM(T) System Cutout Dimensions (inches [mm])

## Power Management

The following paragraphs explain the system power, the power supply, and the effects of excessive heat, electrical noise, and line voltage variation of the 3700 unit.

### System Power

Using isolation transformers on the incoming AC power line to the system is always a good practice. An isolation transformer is especially desirable in cases in which heavy equipment is likely to introduce noise onto the AC line.

The isolation transformer can also serve as a step-down transformer to reduce the incoming line voltage to a desired level. The transformer should have a sufficient power rating (units of volt-amperes) to supply the load adequately.

Proper grounding is essential to all safe electrical installations. Refer to the relevant Federal, State/Provincial, and local electric codes, which provide data such as the size and types of conductors, color codes and connections necessary for safe grounding of electrical components. The Federal electric code specifies that a grounding path must be permanent (no solder), continuous, and able to safely conduct the ground-fault current in the system with minimal impedance (minimum wire required is #18 AWG, 1 mm).

Observe the following practices:

- Separate ground wires (P.E., or Protective Earth) from power wires at the point of entry to the enclosure. To minimize the ground wire length within the enclosure, locate the ground reference point near the point of entry for the plant power supply.
- All electrical racks or chassis and machine elements should be Earth Grounded in installations where high levels of electrical noise can be expected. The rack/chassis should be grounded with a ground rod or attached to nearby Earth structure such as a steel support beam. Each different apparatus should be connected to a single Earth Ground point in a “star” configuration with low impedance cable. Scrape away paint and other nonconductive material from the area where a chassis makes contact with the enclosure.
- In addition to the ground connection made through the mounting bolt or stud, use a one-inch metal braid or size #8 AWG wire to connect between each chassis and the enclosure at the mounting bolt or stud.

## Power Supply

The power supply on 3700 models provides 200 Watts of output power throughout the system's temperature range. The power available for expansion is limited, as shown in Table 2-1.

Table 2-1. Available Expansion Current

Voltage	Available Current
	3712 & 3715 models
+3.3 VDC	10 A
+5.0 VDC	6 A
-5.0 VDC	0.2 A
+12.0 VDC	4.9 A
-12.0 VDC	0.5 A
<b>Caution:</b> +5V and +3.3V combined not to exceed 36 watts -5V and -12V combined cannot exceed 8 watts	

## Excessive Heat

The units withstand temperatures from 0° to 50°C, and are fan-cooled. To keep the temperature in range, the cooling air of the system must not exceed 50°C. Allocate proper spacing between internal components installed in the enclosure. Units with standard BIOS release 1.3 or greater will automatically throttle down the CPU speed if the temperature exceeds the maximum allowed CPU temperature.

## Electrical Noise

Electrical noise is seldom responsible for damaging components, unless extremely high energy or high voltage levels are present. However, noise can cause temporary malfunctions, which can result in hazardous machine operation in certain applications. Noise may be present only at certain times, may appear at widespread intervals, or in some cases may exist continuously.

Noise commonly enters through input, output, and power supply lines, and may also be coupled through the capacitance between these lines and noise signal carrier lines. This usually results from the presence of high voltage or long, close-spaced conductors. When control lines are closely spaced with lines carrying large currents, the coupling of magnetic fields can also occur. Use shielded cables to help minimize noise. Potential noise generators include switching components, relays, solenoids, motors, and motor starters.

Refer to the relevant Federal, State/Provincial, and local electric codes, which provide data such as the size and types of conductors, color codes and connections necessary for safe grounding of electrical components. It is recommended that the high voltage and low voltage cabling be separated and dressed apart. In particular, the AC cables and switch wiring should not be in the same conduit with all communication cables.

## Line Voltage Variation

The unit's power supply is built to operate with input voltage ranges of 100 VAC and 240 VAC, while still allowing the system to function within its operating margin. As long as the incoming voltage is adequate, the power supply provides all the logic voltages necessary to support the processor, memory, and I/O.

In cases in which the installation is subject to unusual AC line variations, use a constant voltage transformer to prevent the system from shutting down too often. However, a first step toward the solution of the line variations is to correct any possible feed problem in the distribution system. If this correction does not solve the problem, use a constant voltage transformer.

The constant voltage transformer stabilizes the input voltage to the 3700 unit by compensating for voltage changes at the primary in order to maintain a steady voltage at the secondary. When using a constant voltage transformer, check that the power rating is sufficient to supply the unit.

## AC Power Cable

A power cable must be created to supply power to the unit. The following materials are needed:

- A three-position power connector (supplied)
- A braid/foil shielded power cable, terminated at power source end, with three #18 (1.0 mm), #16 (1.3 mm), or #14 (1.6 mm) AWG solid or stranded copper wires, rated 80°C or better

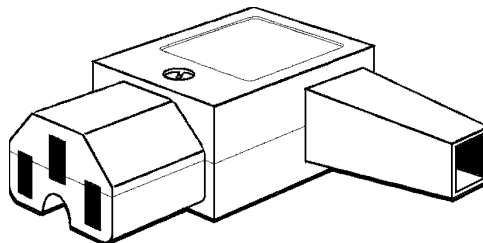

Figure 2-3. 3700 AC Power Connector

Perform the following steps to construct and attach the cable:

1. Cut wire cable to the desired length.
2. Strip 0.25 in [6 mm] of insulation from the end of the conductor wire. No bare wire should be exposed when the cable is connected to the workstation.
3. Tin the wire ends with solder if using stranded wire. This will keep the wire from fraying.

### Warning

When inserting the wire ends of the power cable into the block plug, be sure there is no exposed wire. Trim the wire ends of the cable or cut a new cable if necessary.

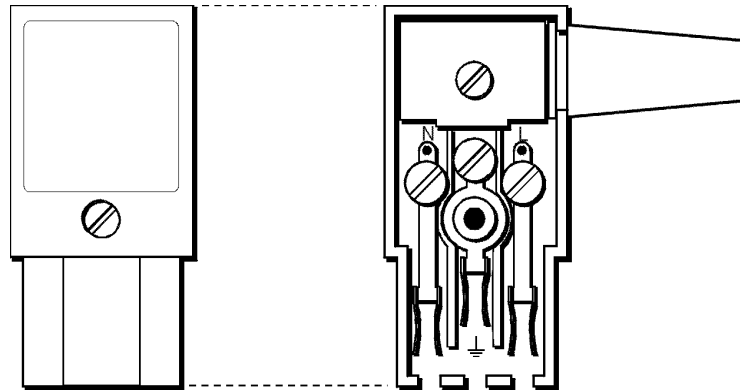

Figure 2-4. Internal View of 3700 AC Power Connector

4. Insert the three wire ends of the power cable into the hole of the connector plug. Bend the Protective Earth ground (PE) wire, the neutral (N) wire, and the line (L) wire around the corresponding screws. Be sure that no bare wires are exposed.
5. Tighten the three screws above the wires to hold them firmly in place.

### Warning

Never tighten the three screws of the block plug when the cable is connected to a power source. The screws are conductive and have full contact with the cable wire.

6. Use the screw provided to secure and strain-relief the power cable inside the connector. Plug the power cable into the power supply located on the side of the unit. Install the plug retainer bracket over the plug (mandatory for hazardous location installations).
7. Once the power cable and other optional interface cables are installed, installation is complete.

### Note

When disconnecting the power cord from the unit, be sure to completely loosen the two securing screws on the retainer bracket.

## Installing Internal Hardware Options

Remove the lid to install internal hardware options.

### Caution

Turn off the unit before installing internal hardware.

**Warning**

Installation of expansion boards may void safety and/or EMC compliance.

**DRAM and Additional DRAM Dual Inline Memory Modules (DIMMs)**

You can order the 3700 system factory-configured for many configurations of DRAM. The system has two 168-pin SDRAM DIMM sites that support 128, 256, and 512 MB options. The maximum amount supported is 512 MB. You can reconfigure the DRAM capacity by changing the DRAM DIMMs on your board. For more information, refer to the AIM3 CPU manual.

**PC/AT™ and PCI Boards**

The following instructions explain how to install PC/AT and PCI boards.

1. Check that the memory and I/O configuration of the board you want to install do not conflict with the CPU and I/O memory maps in your AIM3 CPU board manual.
2. Remove the lid.
3. Remove the screw attaching the plate to the frame from the desired slot.
4. Slide the PC/AT expansion board into the corresponding rail.
5. Push the board into the backplane connectors.

**Caution**

**DO NOT** force the boards or apply uneven pressure.

6. Secure the board by installing the screw through the hole in the board's metal frame and into the top of the track.
7. Replace the lid.

**Warning**

The installation of any additional boards will void the UL Listing for Hazardous Locations compliance.

**Using a Touch Screen**

The 3700 series touch screen complies with environmental specifications and maintains a NEMA 4 seal when panel mounted. The touch screen controller emulates a Microsoft PS/2 mouse.

## Installing the Touch Screen Driver

In order to use the touch screen on your KPMT monitor, you must install the proper driver on the computer hooked to your monitor.

**For computers running Windows® 98, NT, 2000, or XP,** you will be installing the driver `touchbase_windows_kpmt_mons.exe`. This driver can be found in the “Drivers\Touchscreen” folder on the Documentation and Support Library CD that shipped with your monitor. The default setting is serial mode.

1. Create a folder named “Touch” on your desktop or in the root directory of your C: drive, and unzip the files into the folder.
2. Click on the file “setup.exe” and follow the directions. Pro-face suggests that you accept all of the defaults.
3. Calibrate the touchscreen, following the directions in the next section.

### Caution

When using MS-DOS®, the mouse driver must be loaded before the touch screen driver if both a mouse and touch screen are to be supported.

**For computers running MS-DOS®,** you will be installing the driver, `touchbase_dos.zip`. This driver can be found in the “Drivers\Touchscreen” folder on the Documentation and Support Library CD that shipped with your monitor.

1. Create a directory named “Touch” in the root directory of your C:\ drive and unzip the files into the folder.
2. Run the file “install.exe” in the TB458 subdirectory and follow the directions. Pro-face suggests that you accept all of the defaults.
3. Copy all of the batchfile utilities from the Batch Files subdirectory to C:\
4. Add the command `allser.bat` to your `autoexec.bat` file.
5. Re-boot your system.
6. Calibrate the touchscreen, following the directions in the next section.

### Caution

It is recommended that you keep all default setting when installing the driver.

The touch screen drivers are located on the Document and Support Library CD, which is shipped with you unit. Drivers can also be downloaded from <http://www.profaceamerica.com>.

## Calibrating the Touch Screen

You need to calibrate the touch screen in the following cases:

- The cursor does not follow the movement of your finger or pen.
- You adjust the size of the video image or change the video mode.

**For computers running Windows® 98, NT, 2000, or XP:** Before calibrating your touch screen, Profaceamerica strongly recommends altering the following default settings in the calibration program.

1. Go to START/PROGRAMS/UPDD/SETTINGS
2. Click on the Calibration tab.
3. Set the Calibration points to 25.
4. Set the Margin Percentage to 1.

### Note

If the Margin Percentage is set to 0, the calibration may not be correct at the edges of the screen, causing the cursor to jump unexpectedly.

5. Click on the Settings tab.
6. Set the Averaging to 0.
7. Click Apply.

You are now ready to calibrate your touch screen. Follow the instructions found in the following applet to calibrate the touch screen:

**START/PROGRAMS/UPDD/CALIBRATE**

### Note

The touch screen and controller is a matched pair calibrated at the factory. If touch screen and controllers are interchanged calibration may be needed.

**For computers running MS-DOS®,** the touch screen drivers must be loaded before you can calibrate. After the drivers are loaded, switch to **C:\Touch**, and run TBCAL.EXE to calibrate the touch screen:

1. Enter the "H" command for hard calibrate
2. Touch the cross hairs as directed by the calibrate utility
3. Save the settings
4. Exit the calibrate utility with the "X" command

## Custom Logo

You have the option to place a custom label on your unit. Refer to Figure 2-5 for the dimensions and recommended requirements for a customized label. Once a customized label is procured, place the new label over the “Pro-face /Xycom” label.

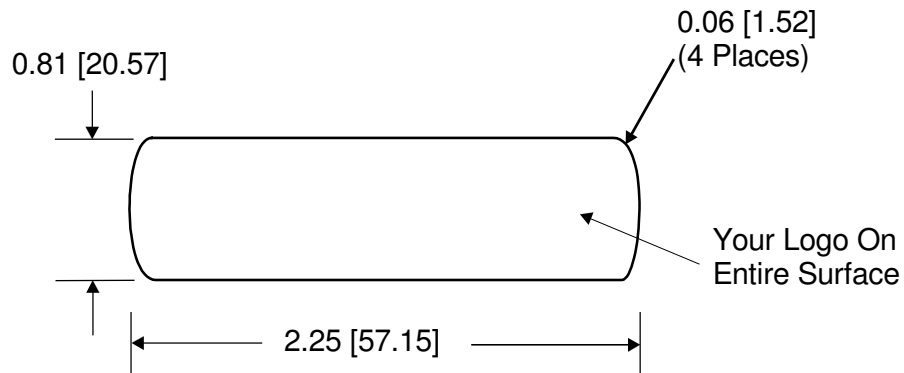

**NOTE: All dimensions are in inches [mm]**

Recommended material: 0.007 [0.176] thick polyester with 3M #468 adhesive on far side.

*Figure 2-5. Logo Label Dimensions*

## Creating Custom Keypad Inserts

You can customize your keypad with keypad inserts to match the function keys that you program. Refer to Figure 2-6 and Figure 2-7 for insert dimensions for the 3712KPM(T). Refer to Figure 2-8 and Figure 2-9 for insert dimensions for the 3715KPM(T). Refer to Figure 2-10 for a keypad insert installation diagram.

### 3712KPM(T) Keypad Inserts

Figure 2-6 and Figure 2-7 show the keypad insert dimensions for the 3712KPM(T).

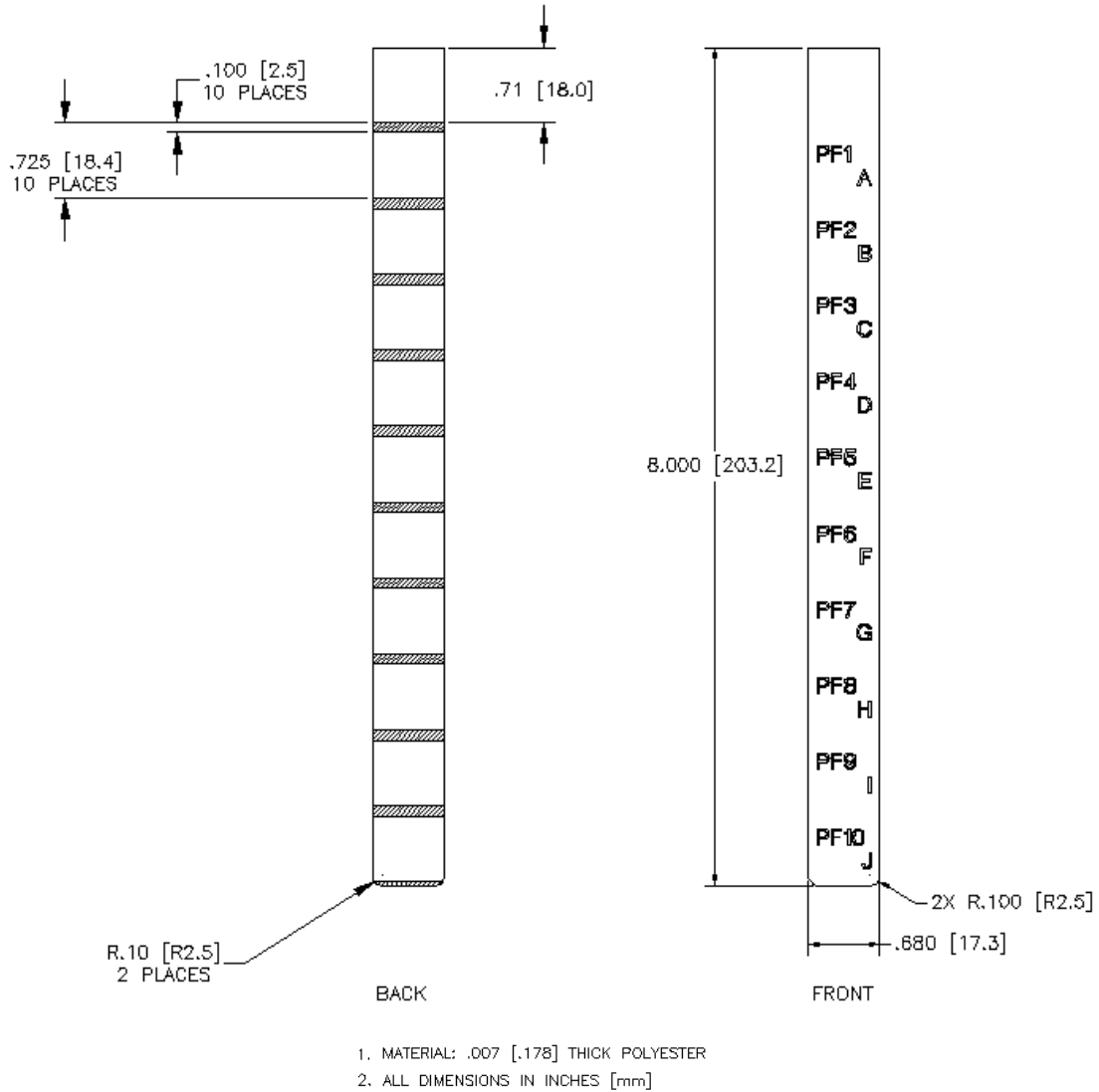

Figure 2-6. 3712KPM(T) Keypad Inserts with Dimensions (PF1 – PF10)

Note : The PF11-PF20 insert has the same dimensions

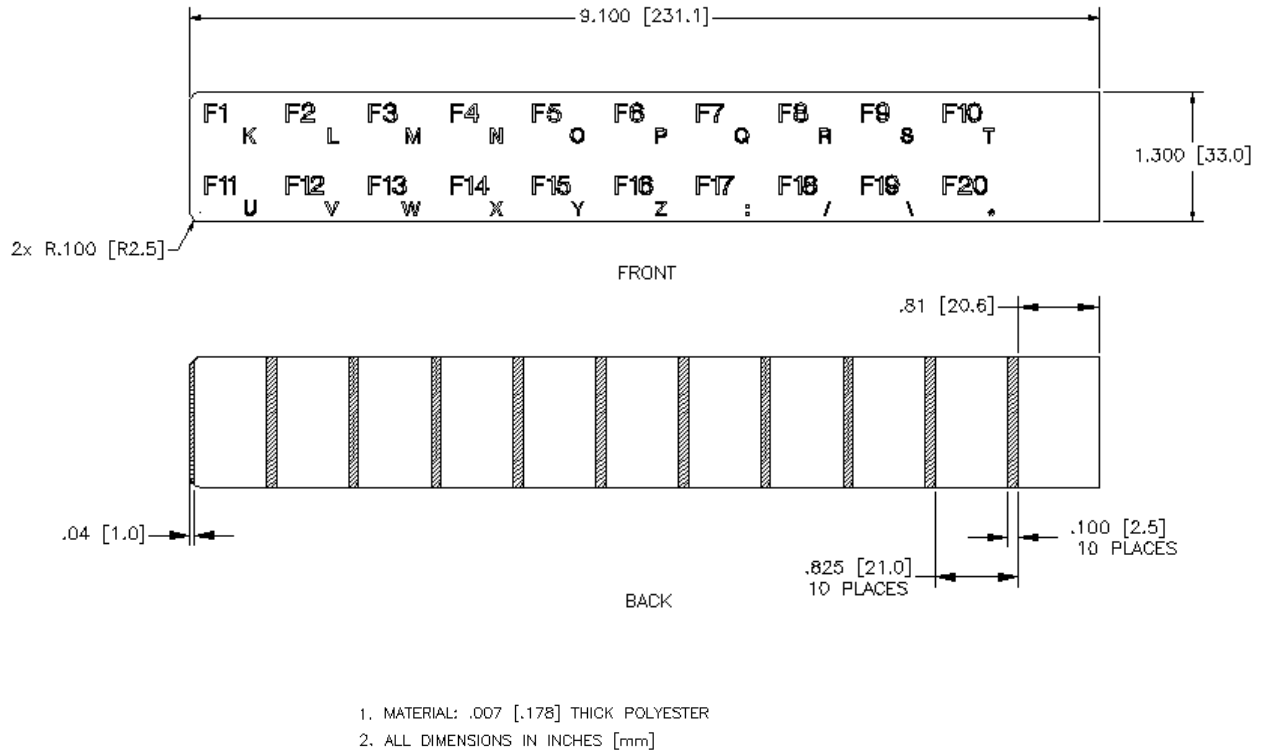

Figure 2-7. 3712KPM(T) Keypad Insert with Dimensions (F1 - F20)

**3715KPM(T) Keypad Inserts**

Figure 2-8 and Figure 2-9 show the keypad insert dimensions for the 3715KPM(T).

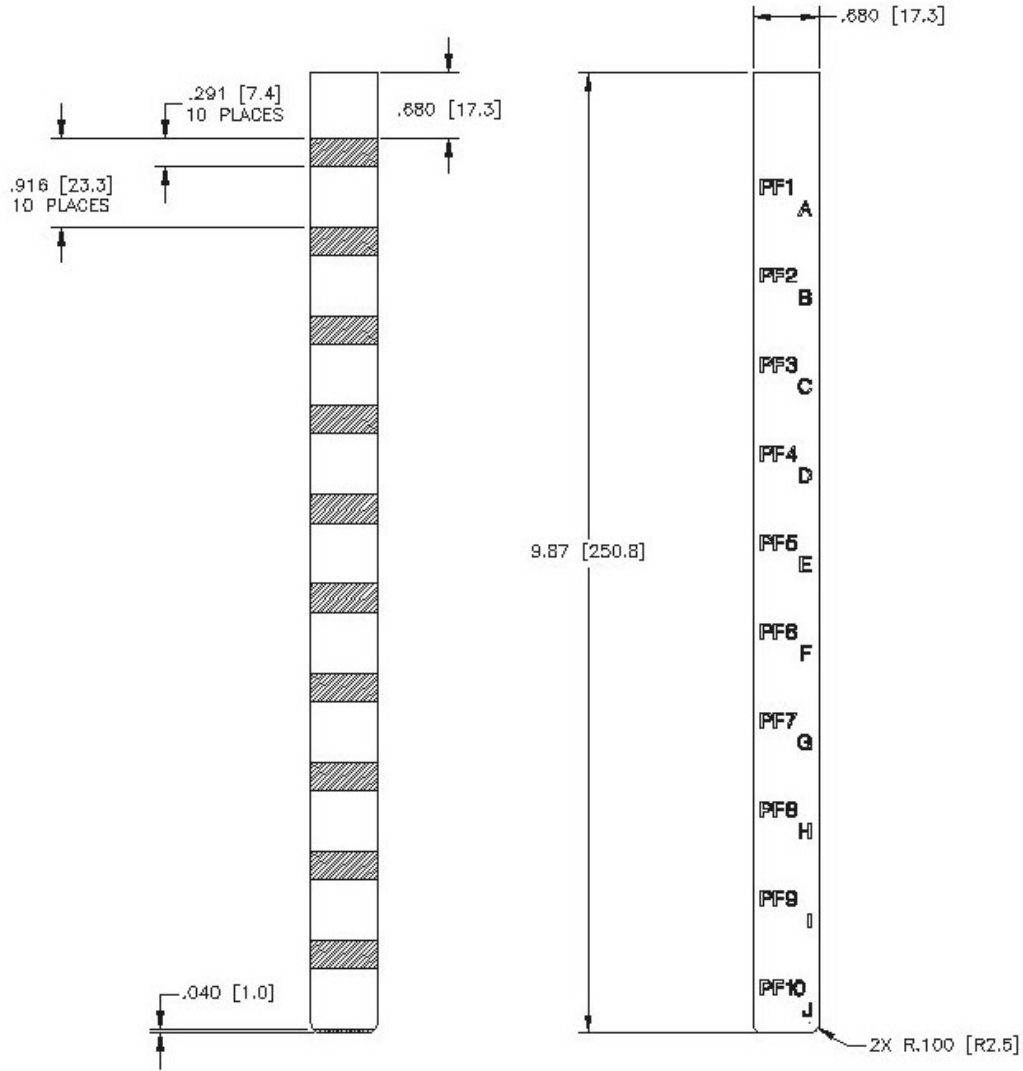

Figure 2-8. 3715KPM(T) Keypad Inserts with Dimensions (PF1 – PF10)

Note : The PF11-PF20 insert has the same dimensions

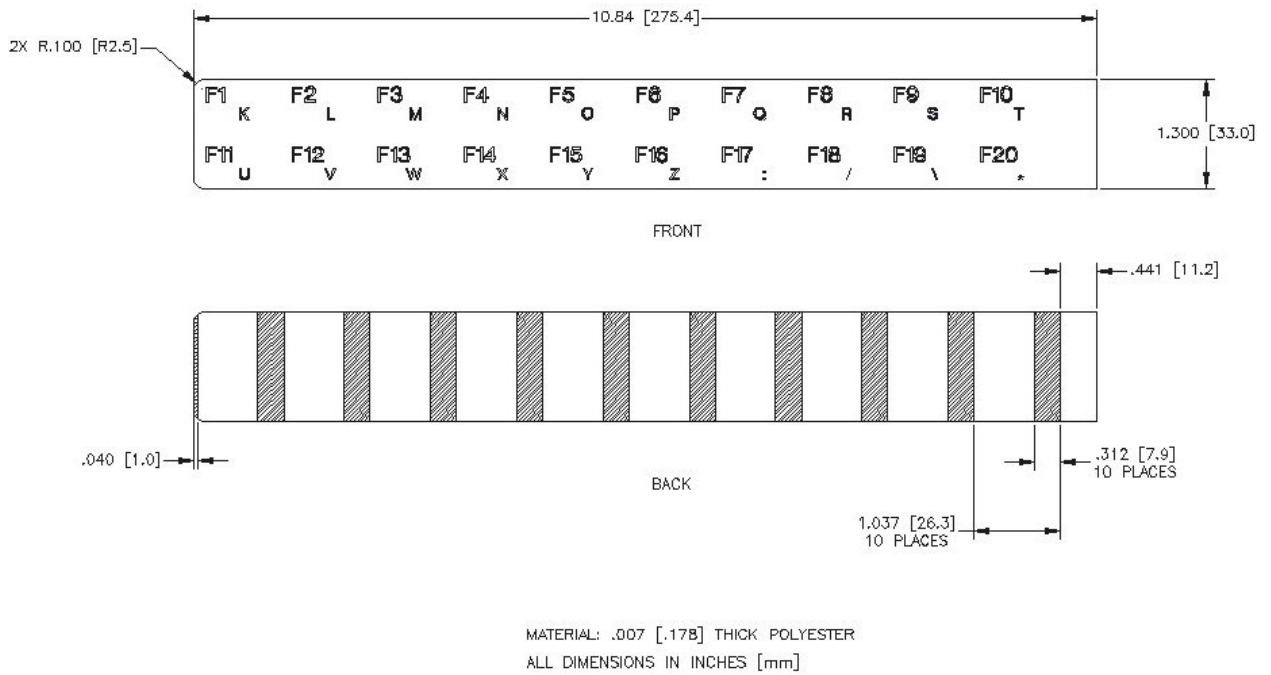

Figure 2-9. 3715KPM(T) Keypad Insert with Dimensions (F1 - F20)

### Keypad Installation Diagram

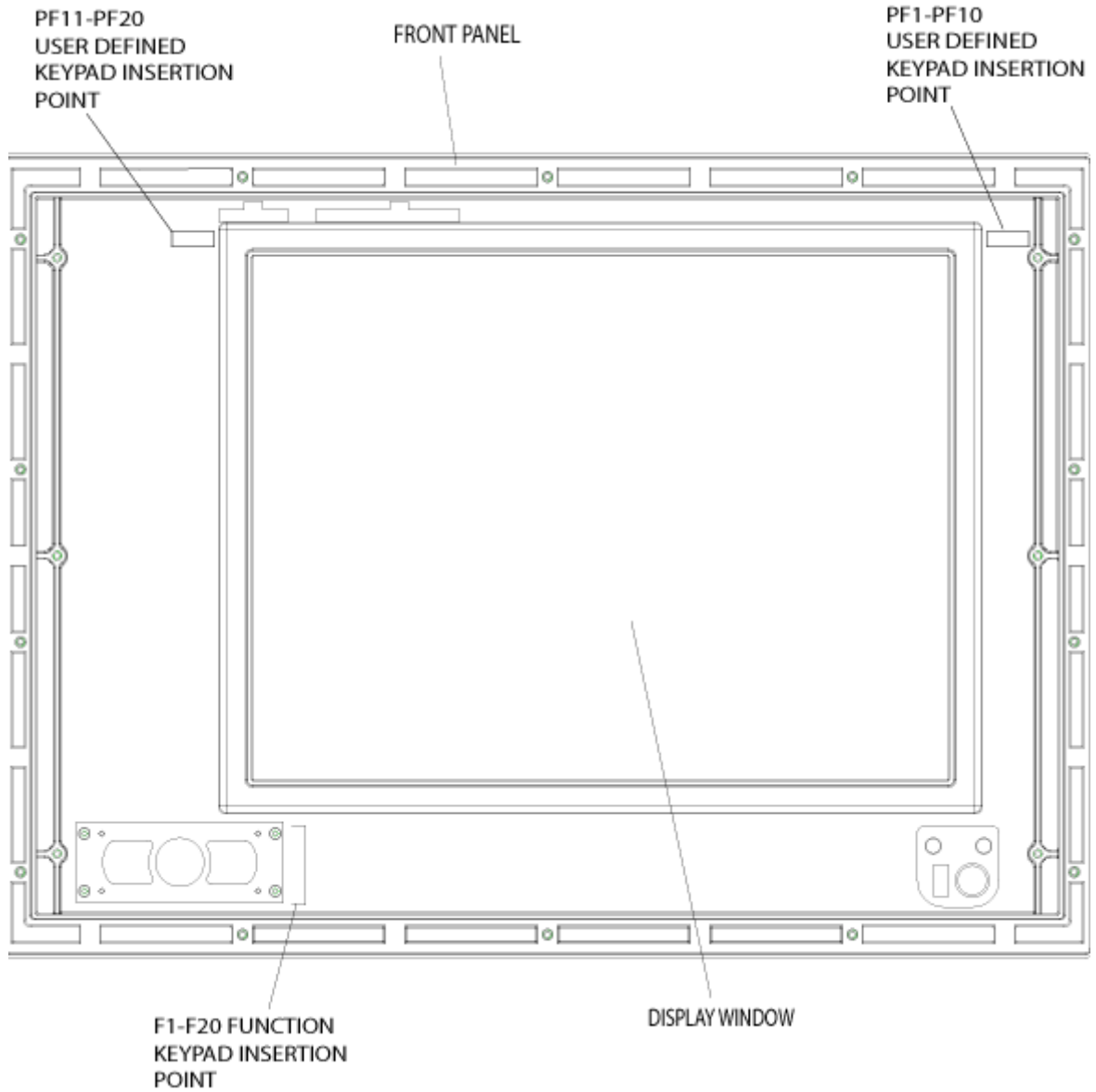

Figure 2-10. Keypad Insertion Diagram

## Hazardous Locations Installation

Pro-face/Xycom designed the 3700 series to meet the requirements of Class I and II, Division 2 Hazardous Locations applications. Division 2 locations are those locations that are normally non-hazardous, but could become hazardous due to accidents that may expose the area to flammable vapors, gases or combustible dusts.

These systems have been designed as non-incendiary devices. They are not intrinsically safe and should never be operated within a Division 1 (normally hazardous) location when installed as described here. Nor should any peripheral interface device attached to these systems be located within Division 1 locations unless approved and/or certified diode barriers are placed in series with each individual signal and DC power line. Any such installations are beyond the bounds of Pro-face design intent. Pro-face accepts no responsibility for installations of this equipment or any devices attached to this equipment in Division 1 locations.

### Warning

When additional cards are added, it is the customer's responsibility to ensure that the cards chosen meet operating conditions for Class I and II, Division 2 Hazardous Locations. Additions and/or modifications without express consent from UL and/or Pro-face will void Hazardous Locations compliance.

It is the responsibility of the customer to ensure that the product is properly rated for the location. If the intended location does not presently have a Class, Division, and Group rating, then users should consult the appropriate authorities having jurisdiction in order to determine the correct rating for that hazardous location.

In accordance with Federal, State/Provincial, and local regulations, all Hazardous Locations installations should be inspected by the appropriate authority having jurisdiction prior to use. Only technically qualified personnel should install, service, and inspect these systems.

### Warning

In order to maintain a safe condition, do not use an external keyboard or mouse when the unit is operating in a hazardous environment.

## Safety Agency Approval

The Pro-face systems have the following approvals:

- *Underwriters Laboratories Inc., UL 1604 Standard for Safety.* Electrical equipment for use in Class I and Class II, Division 2, and Class III hazardous (classified) locations (UL Listed, File E180970)
- *Underwriters Laboratories Inc., UL 508, "Industrial Control Equipment"* (UL Listed, File E107636)

- *Canadian Standard Association, Specification C22.2 No. 213-M1987.*  
Non-incendiary electrical equipment for use in Class I, Division 2  
Hazardous Locations (cUL Listed, File E180970)
- *Canadian Standards Association, Specification C22.2 No. 142, (cUL  
Listed, File E107636)*

### **Warning**

Suitable for use in Class I, Division 2, Groups A, B, C, and D, and Class II, Division 2, Groups F and G Hazardous Locations or non-hazardous locations only.

### **Warning – Explosion Hazard**

Substitution of components may impair suitability for Class I, Class II, Division 2.

### **Avertissement – Risque d'Explosion**

La substitution de composants peut rendre ce matériel inacceptable pour les emplacements de classe I, II, Division 2.

### **Warning – Explosion Hazard**

Do not disconnect equipment unless the power has been switched off or the area is known to be non-hazardous.

### **Avertissement – Risque d'Explosion**

Avant de déconnecter l'équipement, couper le courant ou s'assurer que l'emplacement est désigné non dangereux.

### **Warning – Explosion Hazard**

When in Hazardous Locations, turn off power before replacing or wiring modules.

### **Avertissement – Risque d'Explosion**

Dans les situations hasardees, couper la courant avant de remplacer ou de cabler les modules.

## Definitions

The following Class and Division explanations are derived from Article 500 (Sections 5 and 6) of the United States National Fire Protection Agency National Electric Code (NFPA 70, 1990). The definitions are not complete and are included here only for a general description for those not familiar with generic Hazardous Locations' requirements.

Persons responsible for the installation of this equipment in Hazardous Locations are responsible for ensuring that all relevant codes and regulations related to location rating, enclosure, and wiring are met.

### Class I Locations

Class I locations are those in which flammable gases or vapors are, or may be, present in the air in quantities sufficient to produce explosive or ignitable mixtures.

### Class II Locations

Class II locations are those that are or may become hazardous because of the presence of combustible dust.

### Division 1 Locations

A Division 1 location is one in which flammable or ignitable gasses, vapors, or combustible dusts and particles can exist due the following conditions:

- Normal operating conditions;
- Because of repair, maintenance conditions, leakage, or mechanical failure or abnormal operation of machinery or equipment; or
- Combustible dusts of an electrically conductive nature may be present in hazardous quantities.

#### Note

Pro-face systems are not suitable for installation within Division 1 locations.

#### Note

Electrical equipment cannot be installed in Division 1 locations unless they are intrinsically safe, installed inside approved explosion-proof enclosures, or installed inside approved purged and pressurized enclosures.

### Division 2 Locations

Division 2 locations are listed below:

- Class I volatile flammable liquids or flammable gasses are handled, processed, or used, but confined within closed containers or closed systems from which they can escape only in cases of accidental rupture or breakdown of such enclosures or systems, or in case of abnormal operation of equipment.

- Ignitable concentrations of Class I vapors or gasses are normally prevented by positive mechanical ventilation, but which may become hazardous due to mechanical failure of those ventilation systems.
- Location is adjacent to a Division 1 location.
- Class II combustible dust is not normally in the air in quantities sufficient to produce explosive or ignitable mixtures. Dust accumulations are normally insufficient to interfere with normal operation of electrical equipment or other apparatus. Combustible dust may be in suspension in the air as a result of the following: malfunctioning of handling or processing equipment; combustible dust accumulations on, or in the vicinity of electrical equipment; may be ignitable by abnormal operation or failure of electrical equipment.

## Groups

All electrical equipment that is approved for use in Hazardous Locations must include a group rating. Various flammable and combustible substances are divided into these groups as a function of their individual maximum experimental safe gap (MESG), explosion pressure, and ignition temperature.

Component temperatures and the potential for spark based upon voltage, current, and circuit characteristics, within electrical equipment, will determine what the equipment group rating will be. A device approved for installation within Class I, Group A locations may also be used in Groups B, C, or D.

### Note

Approved Class I equipment may not be suitable for Class II installations. Class I includes Groups A, B, C, and D. Class II includes Groups F, and G.

## Enclosures

The systems are designed for installation within a clean and dry enclosure for both ordinary and Hazardous Locations. The front panel meets the requirements of UL and CSA Type 4, 4X, and 12 enclosures. The enclosure used for Class I Hazardous Locations should have a minimum rating of Type 12 (NEMA 12, IP 5X). However, Type 4 (IP 6X) enclosures are strongly recommended.

Panel flatness and rigidity are important if a proper panel seal is to be maintained. If non-metal type enclosures, such as plastic or fiberglass, are to be used, install a rigid metal stiffener behind the front panel. Failure to do so may result in an inadequate panel seal due to flexure of the front panel material between the stud mounts. Tighten the nuts on the mounting studs to 25 inch-pounds.

The requirements for enclosure fittings, conduit, and wiring vary according to the specific rating of the location and the type of flammable or combustible material involved. Those requirements are beyond the scope of this document and it is the responsibility of the customer to ensure that the installation is compliant with codes and regulations that apply to their specific location. Refer to NFPA 70, Article 500 for specific regulations in the United States.

## Power Switch

The 3700 series does not have a power switch. The amount of input power required by this system classifies the power switch as an incendiary device because the voltage and current across the make/break device are capable of creating a spark.

Hazardous Locations' regulations require that a power switch rated for ordinary locations may be used if it is located in an area specified as non-hazardous. However, limits in cable length between the workstation and the power switch may apply. Otherwise the switch must be compliant with Class I, Division 1 requirements (i.e. intrinsically safe). These switches are built in a manner that prevents the possibility of a spark when contacts are made or broken.

Use suitable UL listed and/or CSA Certified Class I, Division 1 switches in Hazardous Locations. These switches are available from a wide number of sources. It is the responsibility of the customer to ensure that the power switch selected for their installation has the correct Hazardous Locations rating for the location in which it is installed.

## Cable Connections

Division 2 Hazardous Location regulations require that all cable connections be provided with adequate strain relief and positive interlock. Never connect or disconnect a cable while power is applied at either end of the cable.

## Communication Cable Interfaces

All communication cables should include a chassis ground shield. This shield should include both copper braid and aluminum foil. The D-sub style connector housing should be a metal conductive type (e.g., molded zinc) and the ground shield braid should be well terminated directly to the connector housing. Do not use a shield drain wire.

The outer diameter of the cable must be suited to the inner diameter of the cable connector strain relief to ensure that a reliable degree of strain relief is maintained. Always secure the D-sub connectors to the workstation mating connectors via the two screws located on both sides.

### Warning

Never connect or disconnect the communication cables while power is applied at either end of the cable. This may result in an incendiary spark. Permanent damage to the workstation communication components may occur.

### Note

This warning does not apply to the front panel keyboard and USB interface connectors. These connections are nonincendive circuits. Please refer to the Hazardous Locations control drawing on page 34.

### Hazardous Locations Control Drawing

**Warning**  
The following control drawing applies to front panel ports only.

**Class I, Division 2, Groups A, B, C and D, and Class II, Division 2, Groups F and G**

**Hazardous (Classified) Locations**



Notes:

1. Nonincendive Circuit Parameters:

USB Port (Pins 1 to 4)	PS/2 Port (Pins 3 to 4)
$V_{oc} = 5 \text{ VDC}$	$V_{oc} = 5 \text{ VDC}$
$I_{sc} = 3.3 \text{ A}$	$I_{sc} = 3.3 \text{ A}$
$C_a = 10 \text{ uF}$	$C_a = 10 \text{ uF}$
$L_a = 16 \text{ uH}$	$L_a = 4 \text{ uH}$

2. Selected nonincendive Field Wiring Apparatus shall satisfy the following:

Nonincendive Field Wiring Apparatus		Pro-face/Xycom Model 3715KPM and KPMT
$V_{max}$	$\geq$	$V_{oc}$
$I_{max}$	$\geq$	$I_{sc}$
$C_i + C_{cable}$	$\leq$	$C_a$
$L_i + L_{cable}$	$\leq$	$L_a$

3. If the electrical parameters of the cable are unknown, the following values may be used:

Capacitance – 60 pF/ft  
Inductive – 0.20 uH/ft

4. Nonincendive Field Wiring must be installed in accordance with Article 501.4(B)(3) of the National Electrical Code ANSI/NFPA 70.

## Operation and Maintenance

The 3700 series systems have been designed for compliance with relevant spark ignition tests. However, please note that the workstation front panel contrast adjustment tactile switches and keyboard connector are the only make/break components intended to be exercised by the operator in the course of normal operation.

### Warning

In order to maintain a safe condition, never use an external keyboard or mouse connected to side ports when the unit is operating in the presence of a hazardous environment. Use of the front panel USB/keyboard ports is safe only if the control drawing criteria is satisfied as indicated on the control drawing on page 34, and if the device is approved for use in the classified Hazardous Location.

With respect to Hazardous Location installations, always observe the following rules:

1. Always install the workstations within an enclosure suitable for the specific application. General-purpose enclosures may be acceptable for Class I applications but are never acceptable for Class II applications. Type 4 (IP 65) enclosures are recommended even when not required by regulations.
2. If present, keep enclosure doors or openings closed at all times, to avoid the accumulation of foreign matter inside the workstation.
3. Never subject the unit to any installation or service procedures unless power has been removed and the area is known to be non-hazardous. This includes the installation or removal of power cables, communication cables, or removal of the rear cover of the unit.
4. Only technically qualified service personnel should perform all installation and service. These workstations are designed to require no service in the course of normal operation by an operator.

## Chapter 3 – Keypad Utility Program

---

The keypad utility program allows users to redefine any or all of the keypad keys on the unit with new scan codes, using utility software. You must use an external full-stroke PC/AT keyboard to access the utility. This chapter explains how to load the keypad utility, and details how the program's pull-down menus work. Also included in this chapter are the default keypad scan codes.

### Note

Your external full-stroke PC/AT keyboard cannot be redefined by running the keypad utility.

### Note

The keypad switch arrays are disabled while the keypad utility is running.

## Loading the Keypad Utility

### Note

Pro-face keypad utility will only run under DOS 3.2 or better. **The keypad utility will not run in a Windows environment.**

The keypad utility is on the “Documentation & Support Library” CD that shipped with your computer. You will find the self-extracting zip file, *Keypad Utility 1.1 142606-001.exe*, in the folder:

**DRIVERS\Keypad Software\Keypad Utility 1.1 142606-001**

If your computer is running DOS (revision 3.2 or better), create a subdirectory on your hard drive for the files, and extract the files on the disk into that subdirectory. To run the utility, go to the subdirectory and type *kp3util* at the DOS prompt.

If your computer is not running DOS, you will need to extract the files onto a DOS-bootable diskette. The diskette is then inserted into the floppy drive. You will need to reboot your computer for the computer to access the program. To run the utility, type *kp3util* at the DOS prompt.

## Using the Keypad Utility

The keypad utility uses a menu bar and pull-down menu system. All menu bars are displayed across the top of the screen. “Pro-face/Xycom KP3 Utility” and the current menu titles are shown at the bottom of the screen (see Figure 3-1).

A full-stroke keyboard is needed to enter keystrokes while recording a new key macro, editing an existing macro, or entering utility commands. You can redefine all keys on the keypads, except the F/A (Function/Alpha) key. While the utility is running, the keypads are disabled.

Dialog boxes appear for user prompts, and to display error and user advice messages. Any keys used specifically in each menu are shown at the bottom of each screen (see Figure 3-1).

Two keys allow you to exit the menus:

- ESC moves to the previous menu or out of the utility from the Main Menu
- F1 returns to the current menu headings in some of the menus where Exit can be chosen to exit this menu

## Startup

To begin using the keypad utility, type *kp3util* at the prompt (for the floppy drive when no DOS is available, or the CD-ROM drive if it is). The program will bring up the main menu. Open the *def3612.pkm* file in the main menu to program the keypad. (This file contains the default keypad settings for the 3700 series.) Changes to the default file should be saved to a new file with the *pkm* extension. If you do not open a file, the macros pull-down menu will not be available.

### Note

If you make any changes to your keypad and want to set it back to the default settings, open the *pkm* file for your unit (e.g., *def3612.PKM* for 3715KPM) from the File/Open menu, and then download it from the download menu.

### Caution

**Do not save any changes to the default files.**

## Main Menu

Figure 3-1 shows the Main Menu screen. The functions of the pull-down menus are described in the following sections.

### Note

Exit and Download do not have pull-down menus.

### Note

Use F1 to access the menu bar options in the *kp3util* program.

Exit	Files	Macros	Upload	Download	Utilities												
	<table border="1"> <tr><td>Open</td></tr> <tr><td>Close</td></tr> <tr><td>Save</td></tr> <tr><td>Save As</td></tr> <tr><td>Delete</td></tr> <tr><td>Exit</td></tr> </table>	Open	Close	Save	Save As	Delete	Exit	<table border="1"> <tr><td>Function Keys</td></tr> <tr><td>Alpha Keys</td></tr> </table>	Function Keys	Alpha Keys	<table border="1"> <tr><td>KP Ctl. Version</td></tr> <tr><td>Exit</td></tr> </table>	KP Ctl. Version	Exit		<table border="1"> <tr><td>Factory Default</td></tr> <tr><td>Exit</td></tr> </table>	Factory Default	Exit
Open																	
Close																	
Save																	
Save As																	
Delete																	
Exit																	
Function Keys																	
Alpha Keys																	
KP Ctl. Version																	
Exit																	
Factory Default																	
Exit																	
<Company Name> KP3 Utility: MAIN			L-Arrow, R-Arrow, Enter														

Figure 3-1. Main Menu, showing first-level pull-down menus

## Exit

Exit closes any open files and exits the utility. ESC can also be used for this purpose. ESC works for exiting the other menus as well.

## Files Menu

When you choose Files, a pull-down menu will display the following choices: Open, Close, Save, Save As, Delete, and Exit. The following table describes these menu commands.

Table 3-1. Files Menu

Command	Description
Open	Opens a file that contains a macro set for the keypad and loads the contents into memory. Any macro set in memory is overwritten. Once loaded, the macro set is available to edit, view, teach, or download to the keyboard controller.
Close	Clears the macro set from memory and closes the file from which the set came.
Save	Copies the macro set from memory back into its original file. The original file contents are overwritten.
Save As	Creates a new file under the specified name and copies the macro set from memory into it. For example, to define different sets of codes, save each set under a different name and download the one you wish to use.
Delete	Deletes a file.
Exit	Returns to the Main Menu.

You can save files containing keypad macro sets (a macro for each key) on disk, and then load them into memory to view, edit, teach, or download to the keyboard controller. Some of these files may be included in the utility package for use in reconfiguring the keypads for different software packages, and as templates for defining completely new keypad macro sets.

## Macros Menu

### Note

You must have a macro file in memory before the Macros Menu is available. To load a macro file, select the File/Open menu.

When you select Macros, a keypad type pull-down menu is available. This pull-down menu provides the following choices: Function Keys, Alpha Keys, and Exit. Table 3-2 explains the commands in the Macros Keypad Type menu.

Table 3-2. Macros Keypad Type Menu

Command	Description
Function Keys	Selects the function keys on the keypad to view, edit, or teach.
Alpha Keys	Selects the alpha keys on the keypad to view, edit, or teach.
Exit	Returns to the main menu.

After choosing which keys you want to work with (Function or Alpha), another pull-down menu becomes available. This macros edit menu displays the following choices: Exit, View, Teach, and Edit. Table 3-3 explains the commands in the Macros Edit menu.

Table 3-3. Macros Edit Menu

Command	Description
Exit	Returns to the Main Menu.
View	<p>Lets you view, but not edit, the macro for the selected key. When View is chosen, the Exit option is displayed on the menu bar and a graphic representation of the chosen keypad is shown. To return to the Macros Menu, select Exit from the View Menu.</p> <p>To select a key to view, use the arrow keys to position the cursor on the desired key and press ENTER. The macro is displayed as two lines: ASCII and code. The ASCII line displays each keycode as the keys it represents on the full-stroke keyboard. Special labels are used for certain keys (e.g., Spc for space bar, UAr for up arrow, and bk for the break code prefix). The code line is displayed in either Hex or decimal. There is a one-to-one correspondence between the ASCII and code lines.</p> <p>While viewing the macro, the menu bar displays two options: Exit and Hex/Decimal. To access the menu bar, use F1. Exit returns to the View Menu; Hex/Decimal toggles between displaying the macro in hex or decimal format. When Hex is chosen, the keycodes are displayed as hexadecimal value scan codes. When Decimal is chosen, the keycodes are displayed as the decimal equivalent of the hex codes.</p> <p>For example, the macro <i>abc</i> would be displayed as 1C F0 1C 32 F0 32 21 F0 21 in hex, and 28 240 28 50 240 50 33 240 33 in decimal.</p>

Command	Description
Teach	<p>Allows you to record up to 105 keystrokes in a macro. When Teach is selected, a graphic representation of the keypad currently in memory displays. Menu bar choices are Exit, ASCII, and Click OFF. To access the menu bar, use F1.</p> <p>As usual, Exit returns you to the Macros menu. ASCII specifies the format to display the keystrokes as they are entered. ASCII is the default setting. The Click OFF choice is not supported.</p> <p>To select a key to define, use the arrow keys to position the cursor on the desired key and press ENTER. After you select a key, the utility records every keystroke made on the external full-stroke keyboard. The keystrokes are saved in a macro assigned to the chosen key. As the keystrokes are entered, they are displayed using the chosen format.</p> <p>ESC stops recording and returns you to the Teach Menu, so you cannot record the ESC key. However, ESC can be included in a macro by using the editor.</p> <p>Changes made to the macros in the Teach Menu are not programmed until you select Download.</p>
Edit	<p>Displays a graphic representation of the keypad in memory and a menu bar displaying Exit and Click OFF. Exit returns to the Macros menu. Click OFF is not supported.</p> <p>To select a key to edit, use the arrow keys to position the cursor on the desired key and press ENTER. In edit mode, the macro is displayed as two lines. The top line displays the macro in either hex or decimal format, and is the line in which the editing takes place. The bottom line displays the macro in ASCII format; it is not user configurable. The bottom line keeps track of which part of the macro being edited, and is updated by the utility as editing takes place. The insert, delete, and cursor control keys on the full-stroke keyboard are active for editing.</p> <p>When a key is selected from the Edit Macro option, the menu bar displays the following choices: Exit, Cut, Copy, Paste, Codes, Hex, and I/O (Insert/Overtyp). The macro for the chosen key is also displayed. To access the menu bar, use F1.</p>
Edit/Cut	<p>Cut deletes a sequence of scan codes from the macro. To select a section to cut:</p> <ol style="list-style-type: none"> <li>1. Place the cursor on the first character to cut.</li> <li>2. Press F1 (to access the menu bar choices) and select <code>CUT</code>.</li> <li>3. Press ENTER. Cut should still be highlighted, but the cursor will appear on the Edit line. Move the cursor on the last character to cut and press ENTER.</li> </ol> <p>The last character of every macro is the end of the macro (EOM) and cannot be deleted.</p>
Edit/Copy	<p>Copy duplicates a sequence of scan codes from the macro into memory. To select the section to copy:</p> <ol style="list-style-type: none"> <li>1. Place the cursor on the first character to copy. Press F1 and select Copy.</li> <li>2. Press ENTER. Copy should still be highlighted, but the cursor will appear on the Edit line.</li> <li>3. Move the cursor to the last character to copy and press ENTER.</li> </ol> <p>The copied item does not appear on the screen until you select Paste.</p>

Command	Description
Edit/Paste	<p>Paste inserts a sequence of scan codes (which were saved in memory using Copy) into the macro. To paste a sequence of scan codes that were previously copied, position the cursor where you want the text to appear and then press F1. Select Paste and then press ENTER.</p> <p>Codes displays a table of keys and their scan codes in Hex. See the Codes section in this chapter for a complete code listing.</p> <p>Hex/Decimal toggles between displaying the scan codes in Hex and Decimal formats.</p> <p>I/O allows the user to insert text or type over text in the code(s). Use the Insert key on your full-stroke external keyboard to toggle between insert and overtype mode.</p>

### Note

The 3712KPMT and 3715KPMT do not support the programming of special functions such as caps lock, Number lock, or scroll lock.

## Upload Menu

Use the Upload Menu to access the keypad version. As illustrated in Table 3-4, the choices in this menu are Keypad Version and Exit.

Table 3-4. Upload Menu

Command	Description
Keypad Version	Commands the keyboard controller to send its firmware revision number.
Exit	Returns to the Main Menu.

## Download Menu

### Note

Download contains no options. If you select Download, any macro set previously programmed is overwritten.

### Caution

The macros set in memory should be saved before downloading. If they are not saved, all changes will be lost.

Download should be used only after all the keypad keys have been programmed and saved to a \*.pkm file. Selecting Download prior to saving changes will result in a loss of all keypad macro programming.

When you select Download, the program creates a download file called *download.dld* and loads the keypad controller's non-volatile memory with the new macros, which become the new key definitions for the keypad. After the download is complete, the system will prompt the user to cycle power.

## Utilities Menu

When the Utilities menu is selected, two choices are displayed: Factory Default, and Exit. Table 3-5 explains these choices.

Table 3-5. Utilities Menu

Command	Description
Factory Default	Reprograms the keypad macros to the factory default settings. After completion, the system will need to be power cycled.
Exit	Returns to the Main Menu.

## Utility Batch Mode

The Utility Batch Mode can be used to reprogram keypads on multiple units with the same customized keypad macros. This feature is useful because it allows you to do the reprogramming without having to enter the full keypad utility for each individual unit. After you have programmed the first keypad macros, you will need to create a DOS-bootable diskette to run the Utility Batch Mode.

You will need to extract files from the Documentation and Support Library CD-ROM to for the diskette. The necessary files can be found in the folder,

**DRIVERS\Keypad Software\Keypad Utility 1.1 142606-001**

Save the following files from the CD-ROM to the root directory on your DOS-bootable diskette:

- H8flash.exe
- KP3util.exe
- H8fload.mot
- \*.pkm
- codes.pkm
- symbols.pkm
- download.dld

Then, insert the diskette into the unit you want to reprogram and reboot it. At the DOS prompt, type the *kp3util \*.pkm* to run the reprogramming function. This utility can be used on as many units as necessary.

### Note

The \*.pkm file is the macro file you saved in the earlier step. The \* indicates the name you selected for the file.

### Note

The *download.dld* file was created after the last keypad programming process. This includes both new programming and reprogramming the keypad to the factory default settings.

## Keypad Scan Codes

The utility's default keypad keycodes are listed in the following table.

Table 3-6. Default Keypad Keycodes

3712KPM(T) 3715KPM(T)	F/A Key LED Off (Function Mode)			F/A Key LED On (Alpha Mode)		
	Description of Key	Keyboard Equivalent	Make Codes	Break Codes	Keyboard Equivalent	Make Codes
PF1 / A	F21	14 05	F0 05 F0 14	A	1C	F0 1C
PF2 / B	F22	14 06	F0 06 F0 14	B	32	F0 32
PF3 / C	F23	14 04	F0 04 F0 14	C	21	F0 21
PF4 / D	F24	14 0C	F0 0C F0 14	D	23	F0 23
PF5 / E	F25	14 03	F0 03 F0 14	E	24	F0 24
PF6 / F	F26	14 0B	F0 0B F0 14	F	2B	F0 2B
PF7 / G	F27	14 83	F0 83 F0 14	G	34	F0 34
PF8 / H	F28	14 0A	F0 0A F0 14	H	33	F0 33
PF9 / I	F29	14 01	F0 01 F0 14	I	43	F0 43
PF10 / J	F30	14 09	F0 09 F0 14	J	3B	F0 3B
F1 / K	F1	05	F0 05	K	42	F0 42
F2 / L	F2	06	F0 06	L	4B	F0 4B
F3 / M	F3	04	F0 04	M	3A	F0 3A
F4 / N	F4	0C	F0 0C	N	31	F0 31
F5 / O	F5	03	F0 03	O	44	F0 44
F6 / P	F6	0B	F0 0B	P	4D	F0 4D
F7 / Q	F7	83	F0 83	Q	15	F0 15
F8 / R	F8	0A	F0 0A	R	2D	F0 2D
F9 / S	F9	01	F0 01	S	1B	F0 1B
F10 / T	F10	09	F0 09	T	2C	F0 2C
F11 / U	F11	12 05	F0 05 F0 12	U	3C	F0 3C
F12 / V	F12	12 06	F0 06 F0 12	V	2A	F0 2A
F13 / W	F13	12 04	F0 04 F0 12	W	1D	F0 1D
F14 / X	F14	12 0C	F0 0C F0 12	X	22	F0 22
F15 / Y	F15	12 03	F0 03 F0 12	Y	35	F0 35
F16 / Z	F16	12 0B	F0 0B F0 12	Z	1A	F0 1A
F17 / :	F17	12 83	F0 83 F0 12	:	12 4C	F0 12 F0 4C
F18 / /	F18	12 0A	F0 0A F0 12	/	4A	F0 4A
F19 / \	F19	12 01	F0 01 F0 12	\	5D	F0 5D
F20 / *	F20	12 09	F0 09 F0 12	*	12 3E	F0 12 F0 3E

Table 3-6. Default Keypad Keycodes

3712KPM(T) 3715KPM(T)	F/A Key LED Off (Function Mode)			F/A Key LED On (Alpha Mode)		
	Description of Key	Keyboard Equivalent	Make Codes	Break Codes	Keyboard Equivalent	Make Codes
PF11 / (	F31	11 05	F0 05 F0 11	(	12 46	F0 12 F0 46
PF12 / )	F32	11 06	F0 06 F0 11	)	12 45	F0 12 F0 45
PF13 / ?	F33	11 04	F0 04 F0 11	?	12 4A	F0 12 F0 4A
PF14 / ^	F34	11 0C	F0 0C F0 11	^	12 36	F0 12 F0 36
PF15 / %	F35	11 03	F0 03 F0 11	%	12 2E	F0 12 F0 2E
PF16 / \$	F36	11 0B	F0 0B F0 11	\$	12 25	F0 12 F0 25
PF17 / @	F37	11 83	F0 83 F0 11	@	12 1E	F0 12 F0 1E
PF18 / <	F38	11 0A	F0 0A F0 11	<	12 41	F0 12 F0 41
PF19 / >	F39	11 01	F0 01 F0 11	>	12 49	F0 12 F0 49
PF20 / ~	F40	11 09	F0 09 F0 11	~	12 0E	F0 12 F0 0E
CTRL	CTRL <sup>1</sup>	14	F0 14	CTRL	14	F0 14
SHIFT	SHIFT <sup>1</sup>	12	F0 12	SHIFT	12	F0 12
ESC	ESC	76	F0 76	ESC	76	F0 76
ALT	ALT <sup>1</sup>	11	F0 11	ALT	11	F0 11
TAB	TAB	0D	F0 0D	TAB	0D	F0 0D
DEL	DEL	E0 12 E0 71	E0 F0 71 E0 F0 12	DEL	E0 12 E0 71	E0 F0 71 E0 F0 12
F/A						
SPACE	SPACE	29	F0 29	SPACE	29	F0 29
BACKSPACE	BACKSPACE	66	F0 66	BACKSPACE	66	F0 66
1	1	16	F0 16	1	16	F0 16
2	2	1E	F0 1E	2	1E	F0 1E
3	3	26	F0 26	3	26	F0 26
4	4	25	F0 25	4	25	F0 25
5	5	2E	F0 2E	5	2E	F0 2E
6	6	36	F0 36	6	36	F0 36
7	7	3D	F0 3D	7	3D	F0 3D
8	8	3E	F0 3E	8	3E	F0 3E
9	9	46	F0 46	9	46	F0 46
.	.	49	F0 49	.	49	F0 49
0	0	45	F0 45	0	45	F0 45
=	=	55	F0 55	=	55	F0 55
PgUp	PgUp	E0 12 E0 7D	E0 F0 7D E0 F0 12	PgUp	E0 12 E0 7D	E0 F0 7D E0 F0 12
up arr	up arr	E0 12 E0 75	E0 F0 75 E0 F0 12	up arr	E0 12 E0 75	E0 F0 75 E0 F0 12
+	+ <sup>2</sup>	79	F0 79	+	79	F0 79
left arr	left arr	E0 12 E0 6B	E0 F0 6B E0 F0 12	left arr	E0 12 E0 6B	E0 F0 6B E0 F0 12
HOME	HOME	E0 12 E0 6C	E0 F0 6C E0 F0 12	HOME	E0 12 E0 6C	E0 F0 6C E0 F0 12
right arr	right arr	E0 12 E0 74	E0 F0 74 E0 F0 12	right arr	E0 12 E0 74	E0 F0 74 E0 F0 12
PgDn	PgDn	E0 12 E0 7A	E0 F0 7A E0 F0 12	PgDn	E0 12 E0 7A	E0 F0 7A E0 F0 12
down arr	down arr	E0 12 E0 72	E0 F0 72 E0 F0 12	down arr	E0 12 E0 72	E0 F0 72 E0 F0 12
-	- <sup>2</sup>	7B	F0 7B	-	7B	F0 7B

Table 3-6. Default Keypad Keycodes

3712KPM(T) 3715KPM(T)	F/A Key LED Off (Function Mode)			F/A Key LED On (Alpha Mode)		
	Description of Key	Keyboard Equivalent	Make Codes	Break Codes	Keyboard Equivalent	Make Codes
ENTER	ENTER <sup>1</sup>	5A	F0 5A	ENTER	5A	F0 5A
END	END	E0 12 E0 69	E0 F0 69 E0 F0 12	END	E0 12 E0 69	E0 F0 69 E0 F0 12
Left Start	Mouse click (windows start menu)	E0 12 E0 1F	E0 F0 1F E0 F0 12		E0 12 E0 1F	E0 F0 1F E0 F0 12
Explorer	Mouse click (windows pop-up menu)	E0 12 E0 2F	E0 F0 2F E0 F0 12		E0 12 E0 2F	E0 F0 2F E0 F0 12

<sup>1</sup>: Use the keyboard buttons located on the left side of the keyboard, i.e. the buttons normally used with the alpha keys

<sup>2</sup>: Use the keyboard buttons located on the right side of the keyboard, i.e. the buttons normally used with the numeric keys

#### Additional notes:

- F11-F20 = SHIFT F1-F10
- F21-F30 = CTRL F1-F10
- F31-F40 = ALT F1-F10
- END, LEFT START, and EXPLORE keys are available.

## Chapter 4 – Maintenance

---

The 3700 series is designed to withstand the harsh environment of the factory floor. Routine maintenance can help keep your system in good operating condition. Preventive maintenance consists of several basic procedures that will greatly reduce the chance of system malfunction. Schedule preventive maintenance along with the regular equipment maintenance to minimize down time.

### General Preventive Maintenance

Here are some preventive measures you can take:

- *Clean the monitor screen* using a non-residue cleaner such as a mild window cleaning solution or CRT screen cleaner. Take care not to scratch the screen face.
- *Clean or change the fan filter periodically* to ensure that the air circulating in the unit is clean. Wash the filter with warm water and dish soap, and let it air dry. Do not scrub the filter, and do not reinstall it into the unit until it is completely dry.
- *Base your maintenance schedule* on the type of environment the system is in (i.e., if the area is dusty, you should schedule maintenance more often than if it is a dry, clean area). Check the filter often to determine if it needs to be changed ahead of schedule.
- *Remove dust and dirt from PC components.* If dust builds up on heat sinks and circuitry, an obstruction of heat dissipation could cause the unit to malfunction. If dust reaches the electronic boards, a short circuit could occur.
- *Check the connections to I/O modules,* especially in environments where vibration could loosen the connections. Check to see that all plugs, sockets, terminal strips, and module connections are solid.
- *Remove unnecessary articles, such as drawings or manuals, from the unit.* They can obstruct airflow and create hot spots, which cause the system to malfunction.
- *Do not place* noise-generating equipment near the 3700 unit.

### Fuse Replacement

The 3700 unit has no accessible fuse. Return the unit to the factory for fuse replacement.

## Fan Filter Replacement

To change the fan filter, remove the grill and filter as illustrated in Figure 4-1 and replace the filter. Then snap the assembly back into position.

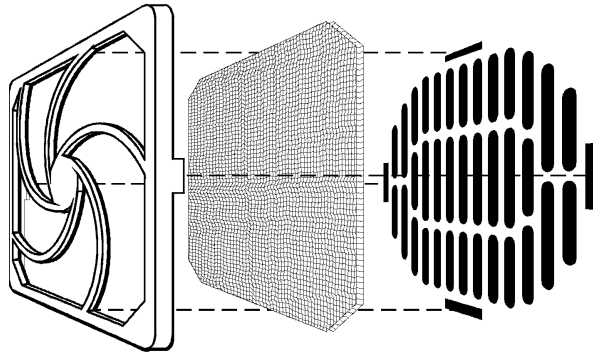

Figure 4-1. Fan Assembly

### Caution

Do not operate the 3700 unit without a fan filter. Dust build-up could cause the unit to malfunction.

## Recommended Hard Drive Preventive Maintenance

Pro-face has recognized that hard drive failures may begin to increase an average of four to five years into the life of most computers used in industrial applications. Therefore, it is our recommendation as a preventive maintenance measure that all hard drives used in these types of applications be replaced before the four to five year time period to avoid any down time related to hard drive failure.

Pro-face believes it is important to keep our customers informed, to offer alternative solutions, and to provide all of our customers with the excellent service they deserve.

Any questions regarding this issue may be directed to our support center at [support@profaceamerica.com](mailto:support@profaceamerica.com)

### Note

Pro-face recommends frequent backups of your hard drive, especially before beginning preventive maintenance procedures.

## System Battery Replacement

The 3700 series AIM3 CPU board includes a coin cell type lithium battery that maintains computer configuration, date, and time information when input power is removed from the system.

If the AIM3 CPU board battery life is ended then the 3700 series computer will no longer maintain the configuration information, date, or time and the battery will need to be replaced. In this case, the following types of error messages will be displayed on the screen at start-up time:

```
ERROR
0271: Check Date and Time Settings
Warning
0251: System CMOS Checksum Bad - Default Configuration
Used

Press <F1> to Resume, <F2> to Setup
```

### BATTERY SPECIFICATIONS:

Part Number: CR2032  
Voltage: 3 V  
Nominal Capacity: 220 mAh

This battery must be a UL Recognized component.

### BATTERY LIFETIME:

Battery current is not consumed while input power is applied to the AIM3 CPU board. However, electrolyte loss through the crimp seal will typically occur at the rate of approximately 0.5% per year at 20 degrees C (68 F). This rate will increase with higher temperatures.

The AIM3 CPU board will consume approximately 6 uA of battery current when power is removed from the motherboard. At this rate, the battery will last approximately 4.2 years in storage at 21 degrees C (70 F). This represents 100% duty cycle, or 'input power off time'. Example:

Battery Capacity = 220 mAh

IC Current Drain = 6 uA

Battery lifetime =  $(0.22 \text{ aH}) / 6 \times 10^{-6} = 36,666 \text{ hours} = 4.2 \text{ years}$ .

When input power is off at the rate of 12 hours per day continuously the battery life should be approximately double the 100% duty cycle time, or 8.4 years at 21 degrees C (50% duty cycle). When input power is off at the rate of 16 hours per day the lifetime should be approximately 12.6 years (33%) duty cycle. However, the electrolyte loss through the crimp seal may reduce the 33% duty cycle lifetime somewhat.

Battery lifetime is inversely proportional to the temperature of the battery. At elevated temperatures the battery life will be decreased.

### BATTERY REMOVAL:

### **Caution**

There is danger of the new battery exploding if it is incorrectly installed. Only technically qualified personnel should perform battery replacement and disposal. Please note the disposal instructions as described in this section.

Please refer to Figure B-2 in Appendix B, 'AIM3 CPU Board Layout'. The lithium battery is identified by the 'BATT1' designation.

#### **TOOLS REQUIRED:**

1. Long Philips Screwdriver for #6 philips screws and captive screw
2. Needle nose pliers
3. Electrical tape to tape the old battery after removal
4. QWERTY keyboard to restore CMOS memory settings after replacing the lithium battery

### **ESD WARNING!**

Protective measures against electrostatic discharge (ESD) must be taken when working inside of any computer. Failure to do so may result in permanent damage to electrical components within. This damage may be immediate or latent (final computer failure may occur at a later date). Be sure to make consistent 'skin to metal' contact with the computer chassis when making contact with any electrical assemblies or components.

#### **TO GAIN ACCESS TO THE BATTERY AND REPLACE:**

1. Remove power from the 3700 series computer. If installed in a panel the computer must be removed and placed screen down on a bench. To work on the computer on the bench you must first place a soft clean cloth on the clean surface of the bench in order to prevent scratches to the display overlay or touch screen. If the computer includes a front panel mouse, then be sure to prop up the bottom edge of the front panel with a soft object in order to prevent damage to the panel mouse controller. Do not rest the face of the computer on the mouse controller.
2. Remove the top cover of the rear chassis (five #6 screws on back)
3. Remove the 'HDD ACCESS' cover. Do not remove the two inner #6 screws on the HDD cover plate. Those screws are used to retain the hard drive. Loosen the two captive screws on the outermost edges marked 'ACCESS'. Pull the HDD cover (with hard drive attached) to remove the assembly.
4. Unplug the hard drive IDE ribbon cable and DC power cable (reference ESD WARNING above)
5. Remove the lower rear chassis cover (six #6 screws on back)

6. Remove the PCI backplane assembly by unscrewing the captive screw on the AIM3 CPU board and two screws on the left side of the rear chassis. The battery at AIM3 CPU board location 'BATT1' is now exposed next to the PCI backplane connector on the AIM3 CPU board.
7. Use needle nose pliers to remove the coin cell battery by depressing the lever on the left side of the battery as shown in the following photograph:

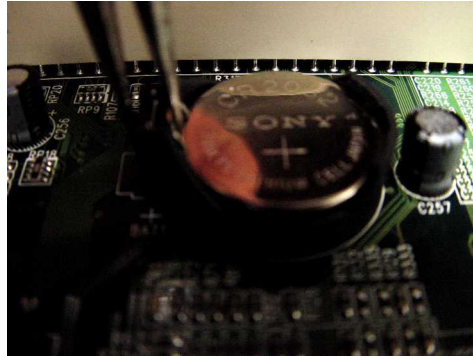

8. Immediately apply electrical tape to the old battery on all sides in order to prevent shorting the battery. The battery may still have charge and a short may cause fire or explosion. Do not dispose of the battery with standard waste. Contact your local waste disposal agency for the address of the nearest battery deposit site.
9. Install the new battery. The '+' sign must be up and exposed. Slide one edge of the battery under the lip of the battery holder as shown in the following photograph and then press down on the battery. It will snap into place.

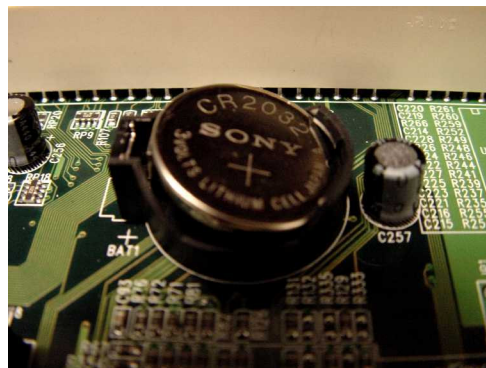

#### TO RE-ASSEMBLE THE 3700 series COMPUTER:

1. Install the PCI backplane assembly by inserting the backplane card edge into the PCI backplane connector on the AIM3 CPU board. Be sure to tighten the captive screw on the lower right side of the PCI backplane assembly first. Then install the remaining two philips screws into the left side of the computer in order to complete the backplane assembly installation.
2. Install the lower rear chassis cover (six #6 screws on back)

3. Plug the IDE ribbon cable into the hard drive. The connector is keyed
4. Plug the DC power cable into the hard drive. The connector is keyed
5. Carefully insert the hard drive assembly back into the spring-loaded slot inside of the 3700 series computer. To do this, be sure that the cables do not lay underneath the hard drive. The HDD ACCESS cover has two guide pins to ensure proper alignment on the upper left and lower right corners. Slide the HDD ACCESS cover guide pins into the holes and gently apply pressure to seat the hard drive into the assembly spring below. Tighten the two captive screws that secure the 'HDD ACCESS' cover.
6. Install the rear chassis top cover (five #6 screws on back).

#### TO SETUP THE CMOS MEMORY:

1. Plug a QWERTY keyboard into the Keyboard port on the side of the 3700 series computer
2. Apply power to the 3700 series computer. The same ERROR and WARNING messages should appear as before battery replacement. This is because the CMOS memory must be setup:

```

ERROR
0271: Check Date and Time Settings
Warning
0251: System CMOS Checksum Bad - Default
Configuration Used

Press <F1> to Resume, <F2> to Setup

```

3. Press the QWERTY keyboard F2 function key to enter CMOS Memory SETUP
4. The SYSTEM TIME and SYSTEM DATE fields are located at the top of the MAIN tab screen. Use the UP and DOWN arrow keys on the keyboard to move from field to field. Use the TAB key to move between the [HH:MM:SS] and [MM/DD/YYYY] sub-fields to enter the present time and date.
5. Press the QWERTY keyboard F10 function key to SAVE AND EXIT.
6. Lithium battery replacement is now complete. The computer should boot with no error or warning messages.

## Product Repair Program

Pro-face's Product Repair & Customization Department (PR&C) restores equipment to normal operating condition and implements engineering changes that enhance operating specifications. Pro-face tests products returned to Pro-face with the standard Pro-face test diagnostics.

Follow the steps below to prepare the unit for shipment:

1. Obtain a Return Merchandise Authorization (RMA) number for your unit by calling your nearest Pro-face Repair Department or Xycom Automation, LLC at 734-429-4971.
2. Please have the following information:
  - Company name, shipping and billing address
  - Type of service desired: product repair or product exchange

- Product model number, part number, quantity, serial number(s), and warranty status
  - Failure mode and failure systems
  - Purchase order number or repair order number
3. Make sure the front panel assembly is properly attached to the unit.
  4. Attach failure information to the unit to speed processing.
  5. Place the unit securely in its original packaging or an equivalent heavy-duty box.
  6. Mark the RMA number on your purchase order and on the outside of the box.
  7. Send the unit to the address given when you receive your RMA number.

## 3700 Front Panel Frame

The 3712 and 3715 front panel frames are made of powder-coated aluminum. The key ingredients are pure polyester, TEPIC-G, titanium oxide, barium sulfate, leveling agent, and carbon black.

### Chemicals Compatible with 3700 Frame

Table 4-1 should be used only as a guide. Specific testing should be conducted to verify that the unit's finish would meet the demands of extreme environments.

Table 4-1. 3700 Front Panel Frame Chemical Compatibility

CHEMICAL	H	C	CHEMICAL	H	C	CHEMICAL	H	C
<b>Acids:</b>			<b>Alkalies:</b>			<b>Solvents:</b>		
Acetic, 10%	F	P	Ammonium Hydroxide	P	P	Alcohols	E	E
Acetic, Glacial	P	P	Calcium Hydroxide	P	P	Aliphatic Hydrocarbons	G	G
Benzene Sulfonic, 10%	F	P	Potassium Hydroxide	P	P	Aromatic Hydrocarbons	G	F
Benzoic	E	E	Sodium Hydroxide	P	P	Chlorinated Hydrocarbons	P	N
Boric	E	E	<b>Acid Salts:</b>			Ketones	F	P
Butyric, 100%	F	P	Aluminum Sulfate	E	E	Ethers	F	P
Chloracetic, 10%	E	E	Ammonium Chloride*	E	E	Esters	F	P
Chromic, 5%	P	P	Copper Chloride*	E	E	Gasoline	E	E
Citric, 10%	E	E	Iron Chloride*	E	E	Carbon Tetrachloride	G	G
Fatty Acids	E	E	Nickel Chloride*	E	E	<b>Organics:</b>		
Fluosilicic	P	P	Zinc Chloride*	E	E	Aniline	P	P
Formic, 90%	P	P	<b>Alkaline Salts:</b>			Benzene	F	P
Hydrobromic, 20%	G	F	Barium Sulfide	E	E	Formaldehyde, 37%	G	G
Hydrochloric, 20%	G	F	Sodium Bicarbonate	E	E	Phenol, 5%	G	F
Hydrocyanic	E	E	Sodium Carbonate	E	F	Mineral Oils	E	E
Hydrofluoric, 20%	P	P	Sodium Sulfide	E	F	Vegetable Oils	E	E
Hypochlorous, 5%	G	F	Trisodium Phosphate	G	F	Chlorobenzene	G	F
Lactic, 5%	F	P	<b>Neutral Salts:</b>					
Maleic, 25%	E	E	Calcium Chloride*	E	E			
Nitric, 5%	F	F	Magnesium Chloride*	E	E			
Nitric, 30%	P	P	Potassium Chloride*	E	E			
Oleic	E	E	Sodium Chloride*	E	E			
Oxalic	E	E						
Phosphoric	G	F						
Picric	G	F						
Stearic	E	E						
Sulfuric, 50%	F	P						
Sulfuric, 80%	P	N						
Tannic	E	E						

**Key:**

E - no attack  
 F - some attack, but useable in some instances  
 G - appreciably no attack  
 P - attacked, not recommended for use

N - rapidly attacked  
 H - hot, 180°F (82.2°C) or boiling point of solvent  
 C - cold, 70°F (21.1°C)  
 \* - and nitrate and sulfate

## Front Panel Overlay

The 3700 front panel polyester overlay may be adversely affected by combinations of chemical environments, temperature, and stress. For this reason, material that may come in contact with the 3700 unit should be carefully evaluated under end-use conditions for compatibility.

## Chemicals Compatible with Overlay

The 3700 front panel overlay withstands more than 24 hours of exposure to the chemicals listed in Table 4-2 without visible change.

Table 4-2. Front Panel Overlay Chemical Compatibility

Ethanol Cyclohexanol Glycol Isopropanol Glycerine Methanol	Acetaldehyde Aliphatic hydrocarbons Petrol Toluene Xylene Benzene	Fluorochlorohydrocarbons Perchloroethylene 1.1.1. Trichloroethane Trichloroethylene Ethylacetate Diethyl ether
Acetone Methyl ethyl ketone Dioxan	Formic acid <50% Acetic acid <50% Phosphoric acid <30% Hydrochloric acid <10% Nitric acid <10% Sulphuric acid <10%	Sodium hypochlorite <20% Hydrogen peroxide <25% Potassium carbonate Washing powders Fabric conditioner
Ammonia <2% Caustic soda <2% Alkalicarbonate Bichromate Potassium ferrocyanide/ferricyanide	Cutting oil Diesel oil Linseed oil Paraffin oil Blown castor oil Silicone oil Turpentine substitute	

## Compatible Cleaning Agents for Overlay

The following list contains known cleaning agents and household products that are compatible with the 3700 front panel overlay. If you want to use a cleaning agent that is not listed below, contact the appropriate manufacturer for compatibility.

Jet Dry®	Ariel®	Downey®	Domestos®
Fantastic®	Persil®	Vim®	Lenor®
Wisk®	Windex®	Vortex®	Formula 409®

## Chemicals Not Compatible with Overlay

The following chemicals and household products are known to be non-compatible with the 3700 front panel overlay:

Concentrated mineral acids	Benzyl alcohol	Tomato juice
Concentrated caustic solution	Methylene chloride	Lemon juice
High pressure steam over 212°F (100°C)		Tomato ketchup

# Chapter 5 – Troubleshooting

---

## Diagnostic Testing

If you suspect that you are having hardware problems with your 3700 series, you can use the Pro-face diagnostic utility to check out the PC's various ports and subsystems. The diagnostic utility is on the Documentation and Support Library CD included with your unit.

### Create Diagnostic Disk

The first task is to create a diagnostic diskette. The following steps can be done on any computer with a CD-ROM drive and a floppy drive:

1. Create a DOS-bootable diskette.
2. Create a temporary folder on the computer hard drive.
3. There is a self-extracting zip file on the Documentation and Support Library CD located in:

**DRIVERS\Computer Diagnostics 99290-001\DOS\xydiag**

Run that program and extract the files to the temporary folder you just created.

4. Copy the extracted files onto the DOS-bootable diskette. This diskette will be inserted directly into the 3700 unit's floppy drive.

### Prepare the System

**Before** starting the system tests, perform the following steps:

1. Place the CPU board jumpers and switches to the factory set positions. Refer to the AIM3 CPU manual for these settings.
2. Plug the female end of the AC power cable into the side of the unit and the male end into a properly grounded outlet.
3. Connect the serial loopback connector(s) and the printer cable to the appropriate connectors, and connect a PC/AT or PS/2 keyboard. Figure 5-1 illustrates the wiring necessary for the loopback connection.
4. Default the CMOS setup to the factory settings.

After completing all of the preceding steps, the 3700 unit is ready for diagnostic testing. Follow the directions in the *Running the Tests* section of this chapter.

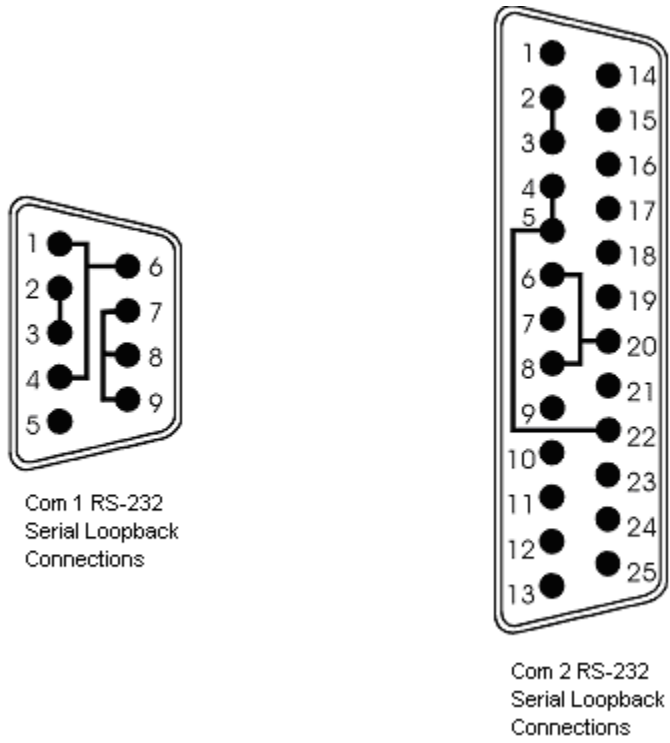

Figure 5-1. Serial Loopback Connections

## Running the Tests

To run the diagnostic tests, insert the DOS-bootable disk you created into drive A. Turn on the computer and the diagnostics program will boot-up. Figure 5-2 shows the Main Menu screen for the program.

```

      Copyright xxxx, <Company Name>, Inc. All rights reserved.
      Diagnostic Tests Sequence/Selection Menu (Rel. xx)
1. WILL pause on error           5. Auto-select tests
2. SINGLE PASS test mode        6. Deselect all tests
3. Save setup to file           7. Quit and exit to DOS
4. Extract setup from a file     8. Return to previous screen
-----
A) RAM Test
B) Video RAM Test
C) Extended RAM Test
D) Real Time Clock Test
E) COM1 Serial Port Test
F) COM2 Serial Port Test
G) COM3 Serial Port Test
H) COM4 Serial Port Test
I) Math Coprocessor Test
J) Video Adjustments Test
K) Video Interface Test
L) Speaker Port Test
M) LPT1: Printer Port Test
N) LPT2: Printer Port Test
O) C: Hard Drive Interface Test
P) D: Hard Drive Interface Test
Q) A: Floppy Drive Interface Test
R) B: Floppy Drive Interface Test
S) Keyboard, Keypad Tests
   = = Test Selected
-----
[ENTER]=START TESTING
Use the letters to move the cursor and select/deselect, or use the arrow
keys to move, then use the [SPACE] key to select/deselect a test or
function.

```

Figure 5-2. Main Menu Screen

### Note

Please read the DIAG.TXT file on the diagnostics disk for detailed information about the tests.

### Caution

Avoid repeated running of any hard disk diagnostic utility if you use the Solid State (Flash) drive option. The Flash drive has a limited number of writes to each logical sector. Repeated writes from a diagnostic utility will prematurely shorten the life of the drive.

## Reinstalling Operating Systems

The 3700 series CPU ships with MS-DOS® preinstalled. Windows® 98, Windows® 2000, Windows® NT, and Windows® XP Professional operating systems are also available. If you need to reinstall an operating system, refer to the appropriate section below. If you want to change operating systems, you will need to use the manufacturer's instruction manual.

### Note

If you need to reinstall the Windows® 98, Windows® 2000, Windows® NT, or Windows® XP Professional operating system, you must have an internal CD-ROM drive or an external parallel port CD-ROM drive.

### MS-DOS® Reinstallation

If you need to reinstall MS-DOS®, refer to the *Pro-face/Xycom Workstation Recovery Media Software Installation Instructions for Microsoft MS-DOS 6.2* (shipped with systems preinstalled with MS-DOS). This document is devoted to the reinstallation of your MS-DOS operating system and drivers, utilizing the Recovery Media provided with your Pro-face/Xycom industrial computer.

### Note

This procedure assumes that the computer hard disk drive has been completely corrupted or replaced.

### Warning

This procedure will destroy data that may exist on the hard disk drive.

### Windows® 98 Reinstallation

If you need to reinstall the Windows® 98 operating system, refer to the *Pro-face/Xycom Workstation Recovery Media Software Installation Instructions for Microsoft® Windows® 98\_SE* (shipped with systems preinstalled with Windows 98). This document is devoted to the reinstallation of your Microsoft Windows 98 operating system and drivers, utilizing the Recovery Media provided with your Pro-face/Xycom industrial computer.

### Note

This procedure assumes that the computer hard disk drive has been completely corrupted or replaced.

### Warning

This procedure will destroy data that may exist on the hard disk drive.

## Windows® 2000 Reinstallation

If you need to reinstall the Windows® 2000 operating system, refer to the *Pro-face/Xycom Workstation Recovery Media Software Installation Instructions for Microsoft Windows 2000* (shipped with systems preinstalled with Windows 2000). This document is devoted to the reinstallation of your Windows 2000 operating system and drivers, utilizing the Recovery Media provided with your Pro-face/Xycom industrial computer. If you want to install a new operating system or reinstall a current operating system, refer to the operating system's manual for directions.

### Note

This procedure assumes that the computer hard disk drive has been completely corrupted or replaced.

### Warning

This procedure will destroy data that may exist on the hard disk drive.

## Windows NT® Reinstallation

If you need to reinstall the Windows® NT operating system, refer to the *Pro-face/Xycom Workstation Recovery Media Software Installation Instructions for Microsoft® Windows® NT Workstation 4.0* (shipped with systems preinstalled with Windows NT). This document is devoted to the reinstallation of your Windows NT Workstation 4.0 operating system and drivers, utilizing the Recovery Media provided with your Pro-face/Xycom industrial computer.

### Note

This procedure assumes that the computer hard disk drive has been completely corrupted or replaced.

### Warning

This procedure will destroy data that may exist on the hard disk drive.

## Windows XP® Reinstallation

If you need to reinstall the Windows® XP operating system, refer to the *Pro-face/Xycom Workstation Software Installation Instructions for Microsoft Windows XP* (shipped with systems preinstalled with Windows XP). This document is devoted to the reinstallation of your Windows XP operating system and drivers, utilizing the XP CD provided with your Pro-face/Xycom industrial computer. If you want to install a new operating system or reinstall a current operating system, refer to the Windows XP Professional CD-ROM (shipped with systems preinstalled with Windows XP Professional).

**Note**

This procedure assumes that the computer hard disk drive has been completely corrupted or replaced.

**Warning**

This procedure will destroy data that may exist on the hard disk drive.

## Installing Drivers

This section describes how to install the video drivers, the video expansion capability, and the touch screen drivers associated with the 3700 series.

### Video Drivers

Video drivers and the related expansion utilities are on the Documentation and Support Library CD that is included with the documentation kit.

For the AIM3 system, choose the video driver for your operating system from the following directory on the Documentation and Support Library CD:

**DRIVERS\VIDEO\AIM3 142338**

### Video Expansion

This section deals with the hardware expansion capability of the video controller chip in DOS applications.

**Note**

It is *not* necessary to read this section if you are a Windows® or OS/2 user and do not plan to run DOS applications.

Unlike a CRT monitor, a flat panel display has a fixed horizontal and vertical resolution. There are many DOS video modes whose resolution is less than that of a flat panel display. To more efficiently make use of the flat panel display's active area, it is necessary to employ an expansion technique that stretches the lower resolution information to fill the higher resolution of the display.

For example, DOS defaults to VGA video mode 3+. This is an 80-column, 25-row text-only screen whose effective resolution is 640 dots x 400 scan lines. Therefore, the 800 x 600 system display will be only partially filled by the 640 x 400 resolution of this particular mode. The expansion function uses lower resolutions that will better utilize the display by stretching the information in an attempt to fill the display.

Operating systems such as Microsoft Windows® 98 and Windows® NT use display drivers to handle the different flat panel displays. In those cases, expansion is not necessary since there is a specific driver for each resolution display.

Expansion does not add any resolution to the existing information; it simply stretches the information to better fit the display. Text and graphic screens can look somewhat grainy from the process of expansion.

### **Touch Screen Drivers**

If you have a touch screen driver that has been factory-installed, you will also receive, pre-loaded and at no extra charge: MS-DOS®, Windows® 98, Windows® 2000, Windows® NT, and Windows® XP Professional touch screen drivers.

#### **Note**

If you ordered a system pre-loaded with an operating system, the touch screen driver was pre-installed.

You must install the corresponding touch screen driver software if you change the operating system. The touch screen drivers are located on the Document and Support Library CD under:

**DRIVERS\TOUCHSCREEN\TOUCH-BASE**

### **Miscellaneous Drivers**

Refer to your operating system and peripheral manuals for information on installing drivers related to these items.

#### **Note**

For further assistance, contact Pro-face Technical Support at 734-944-0482 or [support@profaceamerica.com](mailto:support@profaceamerica.com).

# Appendix A – Technical Specifications

## Hardware Specifications

Table A - 1 lists the hardware specifications for the 3712KPM(T), 3715T and 3715KPM(T).

Table A - 1. Hardware Specifications

Characteristic	Hardware Specification	
	3712KPM(T)	3715T & 3715KPM(T)
Mechanical		
Height	Front Panel 12.22 in (310.38 mm)	Front Panel 13.97 in (354.84 mm)
Width	Front Panel 19.00 in (482.6 mm)	Front Panel 19.00 in (482.6 mm)
Depth	overall 7.40 in (187.96 mm) behind front panel 6.40 in (162.56 mm)	overall 7.64 in (194.06 mm) behind front panel 6.64 in (168.66 mm)
Weight	front panel protrusion 1.00 in (25.4 mm) 29 lb (13.15 kg)	front panel protrusion 1.00 in (25.4 mm) 37 lb (16.78 kg)
Electrical	AC 100-240 V AC, 50-60 Hz (auto ranging), 5.0 A maximum DC 19-36 VDC, 4.8 A @ 19 VDC typical (20 A maximum) <b>Caution:</b> 4.4A typical @19 VDC does not include power for the expansion slots.	
Power Supply	AC 200 watts DC 300 watts	
Passive Backplane	Four available expansion slots: one ½ length PCI one full length PCI one full length ISA one full length PCI or ISA	
Power available for expansion in AC units	+3.3V 10A maximum +5V 6A maximum -5V 0.2A maximum +12V 4.9A maximum -12V 0.5A maximum <b>Caution:</b> +5V and +3.3V combined cannot to exceed 36 watts -5V and -12V combined cannot exceed 8 watts	
Power available for expansion in DC units	+3.3 V 9 maximum +5 V 7A maximum -5 V 0.54A maximum +12 V 8A maximum -12 V 0.7A maximum <b>Caution:</b> -5V and -12V combined cannot exceed 0.8 amps.	
Mounting	Mount in panel or in 19 in rack	
Flat Panel	12.1" TFT color display	15" TFT color display

Characteristic	Hardware Specification	
	3712KPM(T)	3715T & 3715KPM(T)
Agency Approvals	UL 508 (Listed) UL 1604 (Listed) cUL CSA C22.2, No. 142 (Listed) CUL CSA C22.2, No. 213 (Listed)	
Regulatory Compliance	FCC 47 CFR, Part 15, Class A CE EMI EN55022, Class A IMMUNITY EN61000-6-2 SAFETY EN60950 HARMONICS EN61000-3-2, Class A FLICKER EN61000-3-3	

## Environmental Specifications

Table A - 2 lists the environmental specifications for the 3712KPM(T), 3715T and 3715KPM(T).

Table A - 2. Environmental Specifications

Characteristic	Specification
Temperature	
Operating	0° to 50° C (32° to 122° F)
Non-operating	-20° to 60° C (-4° to 140° F)
Humidity	
Operating	20% to 80% RH, non-condensing
Non-operating	20% to 80% RH, non-condensing
Altitude*	
Operating	Sea level to 10,000 feet (3,048 m)
Non-operating	Sea level to 40,000 feet (12,192 m)
Vibration (5 to 2000 Hz)	
Operating**	0.006 in (0.15mm) peak to peak displacement 1.0g maximum acceleration
Non-operating	0.015 in (0.38mm) peak to peak displacement 2.5g maximum acceleration
Shock	
Operating**	15g peak acceleration, 11 msec duration, ½ sine wave
Non-operating	30g peak acceleration, 11 msec duration, ½ sine wave

\* Consistent with internal component specifications

\*\* These values are with solid state hard drives and not rotating media drives.

# Appendix B – Block Diagram and AIM3 Layout

Figure B - 1 shows the diagram of the AC Block Model; Figure B - 2 shows the layout of the AIM3 CPU board.

## AC Model Block Diagram

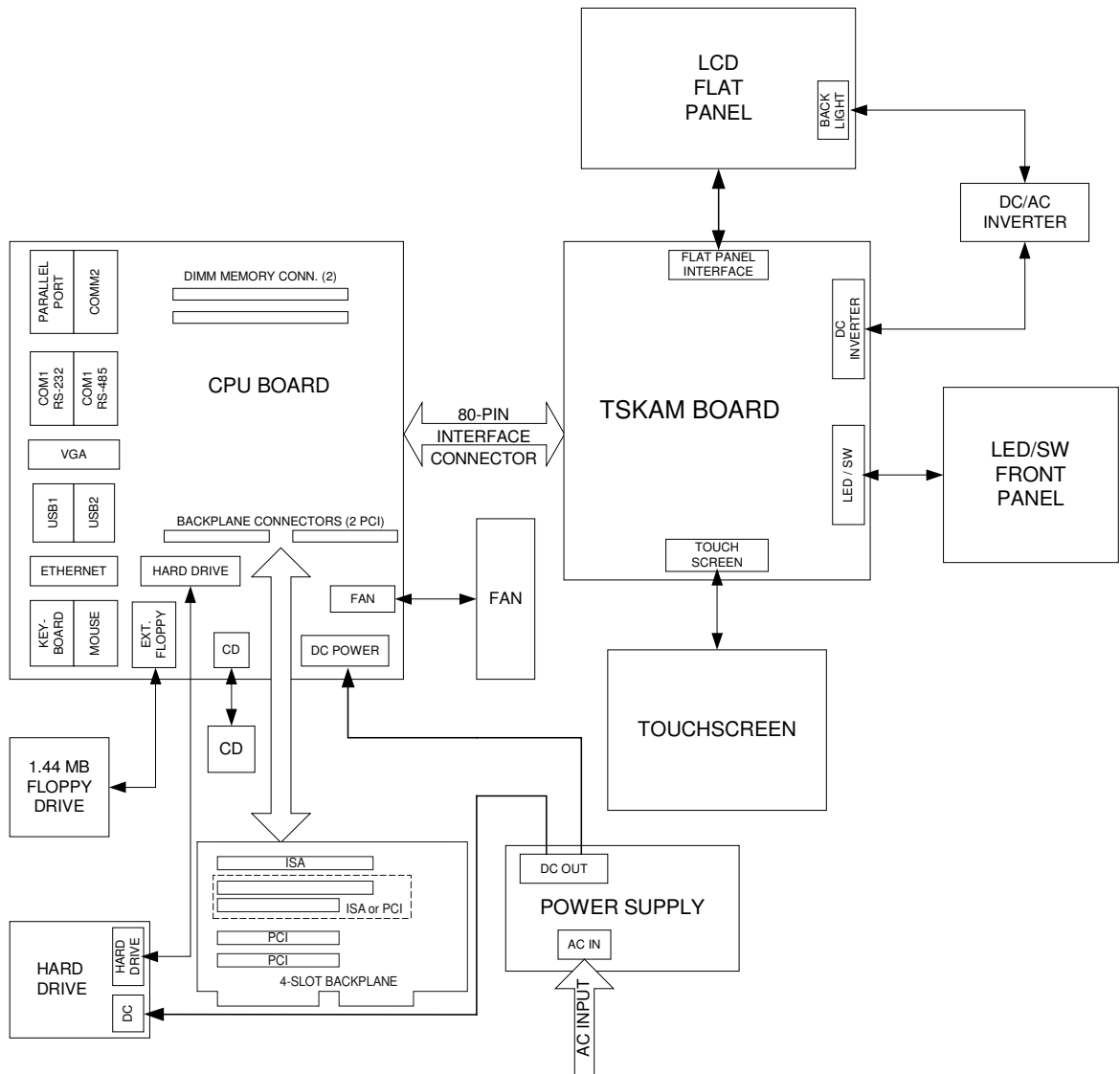

Figure B - 1. 3700 System AC Model Block Diagram

## AIM3 CPU Board Layout

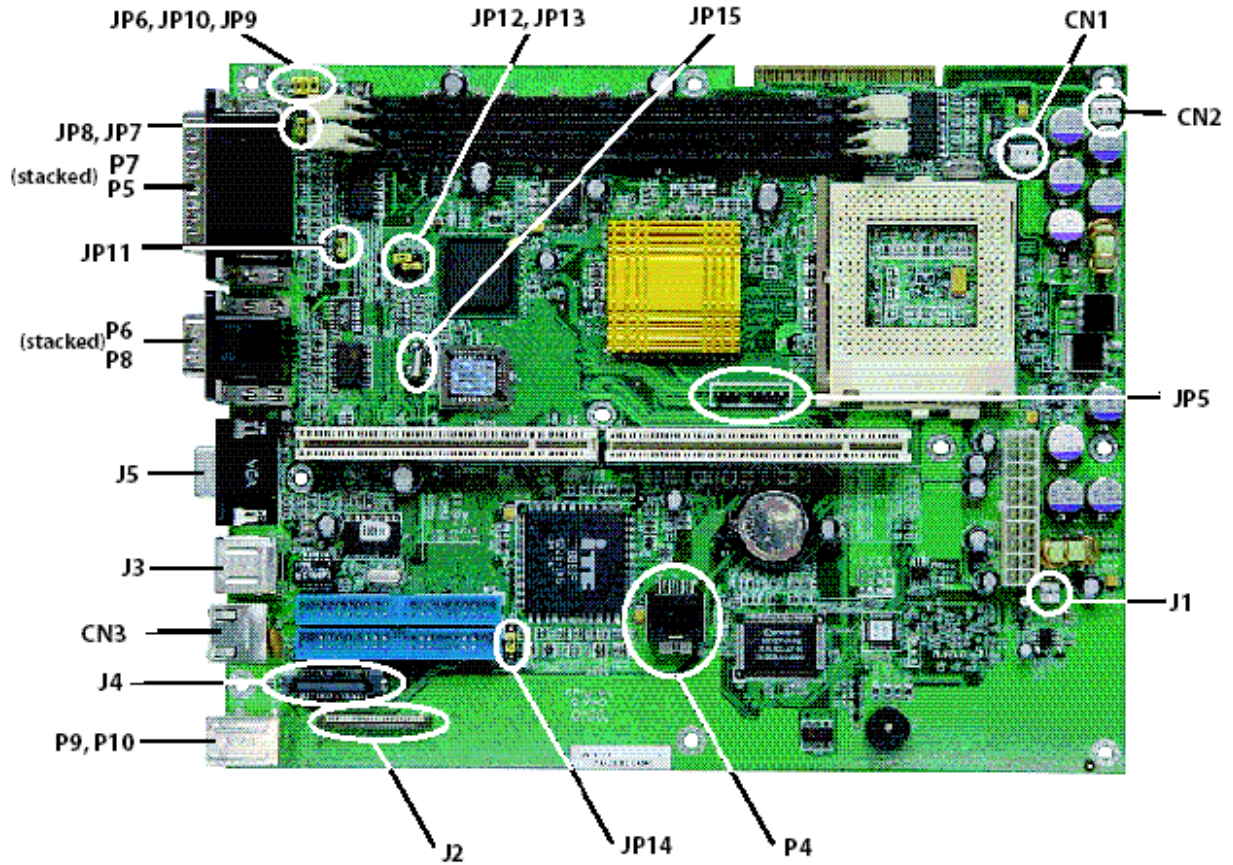

Figure B - 2. AIM3 CPU Board Layout w/Jumper & Connector Locations

## Appendix C – Pinouts

---

This appendix provides the pinouts for the keyboard, mouse, LPT1, COM1, COM2, USB, and VGA connectors. **NC indicates No Connection.**

### Keyboard Port Connector

The following table lists the signal definitions for the keyboard connector. It is a standard PS/2-compatible connector.

*Table C - 1. Keyboard Connector Pinout*

Pin	Signal
1A	KB_DATA
2A	NC
3A	GND
4A	5VFUSE
5A	KB_CLK
6A	NC

### Mouse Port Connector

The following table lists the signal definitions for the PS/2 mini-DIN mouse port connector.

*Table C - 2. Mouse Connector Pinout*

Pin	Signal
1B	MOUSE_DATA
2B	NC
3B	GND
4B	5VFUSE
5B	MOUSE_CLK
6B	NC

## Dual USB Connector (USB1)

The following table lists the signal definitions for the two USB connectors.

*Table C - 3. Dual USB Pinout*

Pin	Description	Pin	Description
1A	5VFUSE	1B	5VFUSE
2A	USBP0-	2B	USBP1-
3A	USBP0+	3B	USBP1+
4A	GND	4B	GND

## Parallel Port Connector (LPT1)

The following table shows the signal definitions for the DB-25 LPT1 connector.

*Table C - 4. Parallel Connector Pinout*

Pin	Signal	Pin	Signal
1	STROBE	14	AUTOFEED
2	PD(0)	15	PERROR
3	PD(1)	16	INIT
4	PD(2)	17	SELIN
5	PD(3)	18	GND
6	PD(4)	19	GND
7	PD(5)	20	GND
8	PD(6)	21	GND
9	PD(7)	22	GND
10	PACK	23	GND
11	PBUSY	24	GND
12	PE	25	GND
13	SELECT		

## Serial Port Connectors

Both RS-232 and RS-485 serial ports are supported. However, only one connector can be used at a time, as all termination is done outside the unit. Refer to the AIM3 manual for different RS-485 connectors.

### COM1

The following table lists the signal definitions for the COM1 DB-9 connectors.

Table C - 5. COM1 Connector Pinout

RS-232		RS-485	
Pin	Signal	Pin	Signal
1A	DCD1	1B	TXD –
2A	RXD1	2B	TXD+
3A	TXD1	3B	TXD TERM –
4A	DTR1	4B	TXD TERM +
5A	GND	5B	GND
6A	DSR1	6B	RXD –
7A	RTS1	7B	RXD +
8A	CTS1	8B	RXD TERM +
9A	RI1	9B	RXD TERM –

#### Note

For TXD termination, connect a 150Ω, ½ watt resistor from pin 3B to pin 4B, with pin 1B connected to pin 3B and pin 2B connected to pin 4B.

For RXD termination, connect a 150Ω, ½ watt resistor from pin 8B to pin 9B, with pin 6B connected to pin 9B and pin 7B connected to pin 8B.

## COM2

The following table lists the signal definitions for the COM2 DB-25 connectors.

Table C - 6. COM2 Connector Pinout

### RS-232

Pin	Signal
1	ORB_GND
2	TXD2
3	RXD2
4	RTS2
5	CTS2
6	DSR2
7	GND
8	DCD2
9	NC
10	NC
11	PB_RESET
12	NC
13	NC

Pin	Signal
14	NC
15	NC
16	NC
17	NC
18	NC
19	NC
20	DTR2
21	NC
22	RI2
23	NC
24	NC
25	NC

## VGA Connector

The following table lists the signal definitions for the VGA DB-15 connector.

Table C - 7. VGA Connector Pinout

Pin	Signal
1	RED
2	GREEN
3	BLUE
4	NC
5	ORB_GND
6	ORB_GND
7	ORB_GND
8	ORB_GND

Pin	Signal
9	Fused VCC
10	ORB_GND
11	NC
12	DDCDAT
13	HSYNC
14	VSYNC
15	DDCCLK

# APPENDIX D – AIM3 CONTROLLER JUMPERS

Table D - 1 shows the position and function of the controller jumpers.

*Table D - 1. Controller Jumpers*

Jumper	Position	Function
JP1 JP2 JP3 JP4		Not used – Not stuffed
JP6	1-2 2-3 √	Provide ground return for +12V/+5V on COM2 connector Do not provide ground return for +12V/+5V on COM2 connector
JP7	1-2 √ 2-3	Allow high side alarm function on COM2 connector Do not allow high side alarm function on COM2 connector
JP8	1-2 √ 2-3	Allow low side alarm function on COM2 connector Do not allow low side alarm function on COM2 connector
JP9	1-2 2-3 √	Supply +12V to COM2 connector Do not supply +12V to COM2 connector
JP10	1-2 2-3 √	Supply +5V to COM2 connector Do not supply +5V to COM2 connector
JP11	1-2 2-3 √	Allow external reset from COM2 connector Do not allow external reset from COM2 connector
JP12	1-2 2-3 √	BIOS detects 40 cond cable (UDMA33 max) Primary IDE BIOS detects 80 cond cable (UDMA66/100 max) Primary IDE
JP13	1-2 √ 2-3	BIOS detects 40 cond cable (UDMA33 max) Secondary IDE BIOS detects 80 cond cable (UDMA66/100 max) Secondary IDE
JP14	1-2 2-3 √	CD-ROM is master on primary IDE CD-ROM is slave on primary IDE
JP15	1-2 √ 2-3	Normal operation Clear CMOS
JP16		This is not a jumper. It allows Arium Emulator to reset the board.

√ indicates default jumper setting

# APPENDIX E – TSKAM SETTINGS

Table E - 1 shows the position and function of the switches on the TSKAM Board (Part Number 142430-001).

*Table E - 1. Jumper and Switch Settings for TSKAM*

Switches/Jumpers	Position/Setting	Function
SW1 (1-4)	Assembly dependent	Keypad type for 9915 SW1.1 ON, SW 1.2,3,4 OFF Keypad type for 3700 All OFF
SW2 (1-4)	All Off	Reserved
JP3	<b>A</b> √ B	<b>Connects H8 keyboard controller pin P8-4/IRQ3* to HOST_KBDATA</b> Connects H8 keyboard controller pin P8-4/IRQ3* to programming header P6 pin 4
JP4	A <b>B</b> √	Connects H8 P8-5 to H8MDATA <b>Connects H8 P8-5 to H8 Programming header P6 pin 3</b>
JP5	A <b>B</b> √	Connects H8 pin P8-1 to H8MCLK <b>Connects H8 pin P8-1 to Program header P6 pin 9</b>
JP7	<b>A</b> √ B	<b>Enables H8 ROM access</b> Disables H8 ROM access
JP8	<b>A</b> √ B	<b>Disconnects H8 STBY* pin from header</b> Connects H8 STBY* pin to Program header P6 pin 11
JP9	<b>In</b> √ Out	<b>Connects remote switch interrupt to H8</b> Disconnects remote switch interrupt from H8
JP14	A <b>B</b> √	3.3V LCD Power <b>5V LCD Power</b>
JP15 <sup>1</sup>	<b>A</b> B	<b>15 inch panel 80 Mhz pixel clock</b> <b>12 inch panel 40 Mhz pixel clock</b>
JP16	In <b>Out</b> √	Front/rear mouse clock routed to H8 <b>Front/rear mouse clock not routed to H8</b>
JP17	In <b>Out</b> √	Front/rear mouse data routed to H8 <b>Front/rear mouse data not routed to H8</b>
JP18	<b>In</b> √ Out	<b>Front/rear mouse clock routed to 87C52</b> Front/rear mouse clock not routed to 87C52
JP19	<b>In</b> √ Out	<b>Front/rear mouse data routed to 87C52</b> Front/rear mouse data not routed to 87C52
JP20 <sup>1</sup>	<b>A</b> B	<b>15 inch panel brightness control</b> <b>12 inch panel brightness control</b>

√ indicates factory default position

<sup>1</sup> indicates factory setting depends on display size

## Appendix F – The RAID-Enabled IPC Option

---

The component most susceptible to shock and vibration in any Industrial PC is the hard drive. Some sources suggest shock mounting the hard drive; unfortunately, shock mounting may cause the hard drive to become more vibration-sensitive at certain frequencies. The most common methods to overcome a susceptibility to vibration are through the use of either solid-state storage media or redundant hard drives. Many of Pro-face/Xycom's Heavy-Duty Industrial PCs offer solid-state media in the form of CompactFlash™ or solid-state hard drives. While many storage sizes are available, the cost of solid-state drives rises considerably as the required drive size increases.

A second approach is to use RAID. (RAID stands for Redundant Array of Independent Disks.) In essence, RAID is two or more hard drives hooked up to the same controller, either SCSI or IDE. The RAID controller can "stripe" or "mirror" data. Striping (RAID 0) is used to read and write to many disks at once to increase hard drive performance, while mirroring (RAID 1) allows the same data to be available on two or more drives.

There are two methods to implement a RAID solution – via software or dedicated hardware. Pro-face has chosen a hardware solution because software solutions are more limited, and require a Windows® 2000 or 2003 Server.

Pro-face's hardware RAID solution utilizes the Adaptec ATA RAID 1200A, a PCI IDE<sup>3</sup> RAID controller card. This controller card is installed in the PC, and the array drives are connected to it, instead of to an IDE controller. Most PCs use an IDE controller to interface between the system and the hard disks. The RAID controller occupies a single PCI slot, so you need to verify the available expansion in your Industrial PC for the application. RAID 1 with two hard drives was chosen as the optimal solution for creating a more robust, fault-tolerant system in the Pro-face/Xycom 1507, 3700 Series, and 1600 Series of Heavy-Duty Industrial PCs. Pro-face has chosen to support Windows® 2000 and Windows® XP for these RAID-enabled assemblies for optimal and reliable performance.

### Note

When installed, the RAID controller bypasses the disk controller on the AIM3 board that runs the disk activity light. Therefore, the disk activity light on the 3700 Series units will not function for the HDDs once the RAID controller is installed. However, the disk activity light will function for the CD-ROM, CompactFlash or any X-Bay units, as the RAID controller does not bypass these items.

In a RAID 1 system, there is a primary and a secondary hard drive. The RAID controller writes to both drives, but only reads from the primary drive. If the RAID

---

<sup>3</sup> ATA and IDE are used interchangeably in this context. IDE stands for Integrated Drive Electronics; ATA stands for Advanced Technology Attachment. Both terms refer to the type of controller used in PCs.

controller detects any problems with the primary drive, it switches over to the secondary drive (which has an exact copy of all data on the primary drive) and informs the operator of the switchover. If the RAID controller should detect any problems with the secondary drive, it stops writing to it and informs the operator of the problem. In either case, the operator can schedule a time to replace the failed drive.

### **Note**

The RAID-Enabled Industrial PC is configured at time of manufacture. The RAID controller is not available as a user-installable upgrade.

When you order a RAID-enabled Industrial PC, the Adaptec controller will be installed and configured in the unit at the Pro-face plant. And, in addition to the items listed in Chapter 2, you will receive the Adaptec ATA RAID 1200A Installation and User's Guide, and the Adaptec RAID driver disk. These items will help you to understand and use your RAID-Enabled PC. The Installation and User's Guide covers:

- Installation of the Adaptec controller
- Using the BIOS array Configuration Utility
- Installation of the device driver
- Using the ATA RAID management software

There is also a troubleshooting section to assist you with any questions that may arise. You may also contact Pro-face Technical Support at [support@profaceamerica.com](mailto:support@profaceamerica.com) or (734) 944-0482 for assistance.

## Index

Access		
floppy disk drive .....	10	
keyboard port .....	6	
AIM3		
jumpers .....	70	
Battery .....	48	
Bottom panel .....	10	
Cable		
communication cable interface .....	33	
connections .....	33	
Class I locations .....	31	
Class II locations .....	31	
COM ports .....	8	
COM1 connector .....	68	
Connectors		
AIM3+		
COM1 .....	68	
parallel port .....	67	
VGA .....	69	
keyboard .....	66	
mouse .....	66	
Custom logo .....	23	
Cutout dimensions		
system .....	29	
Definitions		
class and division .....	31	
DIMM .....	20	
Display .....	4, 6	
Division 1 locations .....	31	
Division 2 locations .....	31	
Documentation kit .....	11	
DRAM .....	20	
Driver		
touch screens .....	21	
Drivers		
installing .....	60	
miscellaneous .....	61	
touch screen .....	61	
video .....	60	
Drives		
floppy disk .....	10	
Dual Inline Memory Modules .....	20	
Enclosures .....	32	
Fan .....	10, 46	
filter replacement .....	47	
Features		
standard .....	1	
Floppy drive		
access .....	10	
Fuse		
replacement .....	46	
Groups .....	32	
Heat, excessive .....	17	
Installation		
DRAM .....	20	
driver .....	60	
hazardous locations .....	29	
operating systems .....	58	
PC/AT and PCI boards .....	20	
Jumper settings		
AIM3 CPU board .....	70	
TSKAM .....	71	
Keyboard		
connectors .....	66	
Keyboard port .....	6, 8	
Keypad Inserts .....	24, 26	
Keypad Utility Program .....	36	
LEDs .....	4, 6	
Line voltage, variation .....	18	
Logo, custom .....	23	
Maintenance .....	46	
battery .....	48	
general .....	46	
hard drive .....	47	
Mouse port .....	8, 66	
Noise, electrical .....	17	
Operating systems		
installation .....	58	

Parallel port connector .....	67	Preparing the system .....	12
PC/AT installation and PCI boards .....	20	Preventive maintenance .....	46
Pinouts		battery .....	48
COM1 .....	68	general .....	46
COM2 .....	69	hard drive .....	47
keyboard connector .....	66	Printer port .....	8
mouse connector .....	66	Product Repair Program .....	51
parallel port .....	67	Repairs and service .....	51
VGA connector .....	69	Returning a Unit .....	51
PKIM utility		Serial port connectors .....	68
Download menu .....	41	Serial ports .....	8
Exit menu .....	38	Service and repairs .....	51
Files menu .....	38	Switch settings	
Macros Keypad Type Menu .....	39	TSKAM .....	71
Main menu .....	37	System	
Upload menu .....	41	maintenance .....	35
using .....	36	operation .....	35
Utilities menu .....	42	System Power .....	16
Ports		Touch screen drivers .....	61
COM .....	8	Touch screens	
keyboard .....	8, 66	calibrating .....	22
mouse .....	8, 66	driver .....	21
parallel .....	8, 67	TSKAM	
printer .....	8	jumper settings .....	71
serial .....	8	switch settings .....	71
video .....	8	using the PKIM Utility .....	36
Power		Utility Batch Mode .....	42
system .....	16	VGA connector .....	69
Power connector .....	10	Video drivers .....	60
Power receptacle .....	10	Video expansion .....	60
Power supply .....	17	Video port .....	8
Power switch .....	32		

143311 (H)

---

Xycom Automation, LLC.  
750 North Maple Rd.  
Saline, MI 48176  
Phone: 734-429-4971  
Fax: 734-429-1010

<http://www.profaceamerica.com>

Canada Sales: 905-607-3400  
Northern Europe Sales: +44-1604-790-767  
Southern Europe Sales: +39-011-770-53-11

