

PRO-FACE OPERATOR INTERFACES

PRODUCT DATA SHEET



AGP3300-L1-D24



AGP3300L Advanced HMI

5.7" Multi-Port Operator Interface Touch Screen with Simultaneous Driver Support

- Crisp, Clear, Bright 320x240 Resolution Monochrome Display
- 64-bit RISC 133Mhz CPU for Ultra-Fast Screen Refresh and Data Sampling
- No Grid Analog Touch Panel for Improved Visibility and Precise Part Placement
- Supports Up to Two Protocol Drivers Simultaneously
- High Speed Application Transfer, 10 Times Faster than Conventional Operator Interfaces
- 10/100 Base-T Ethernet, USB, Serial (MPI) and CompactFlash™ Communication Interfaces
- High-Definition Part Images and Multi-Language Support

PRODUCT OVERVIEW

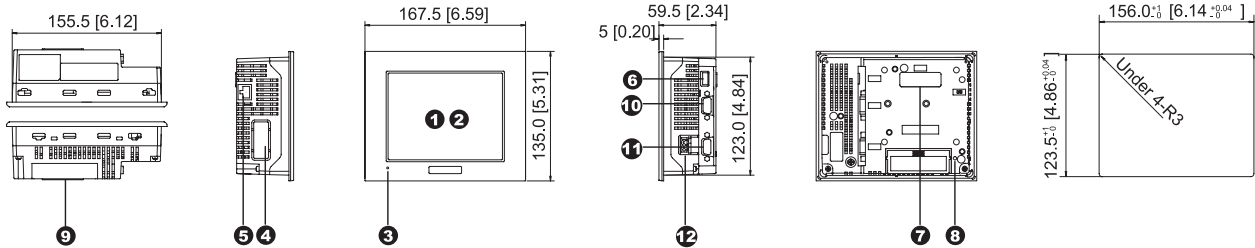

AGP-3300T(AC type) unit shown.

- | | | |
|--|---|--|
| <ul style="list-style-type: none"> ❶ Display ❷ Touch Panel ❸ Status LED ❹ Expansion Communication Feature Interface 1 ❺ 10/100 Base-T Ethernet Interface (LAN) (RJ45) | <ul style="list-style-type: none"> ❻ USB 1.1 Type A Interface (Host)
One Port for download, bar-code, printer or other USB device ❼ Optional Communication Module Interface 2 ❽ CF Card Access LED ❾ CompactFlash™ Card Access Cover
(CF cards up to 512MB available) | <ul style="list-style-type: none"> ❿ Serial Interface (COM1)
RS-232C/RS-422 serial interface. D-sub 9-pin plug type connector. Communication method is switched via software. ⓫ Serial Interface (COM2)
RS-422/RS-485 MPI (187kbps) serial interface. D-sub 9-pin socket type connector. ⓬ Power Plug Connector |
|--|---|--|

COMMUNICATION CAPABILITY

Simultaneous Dual-Protocol Support

Two different protocols can be active at one time.

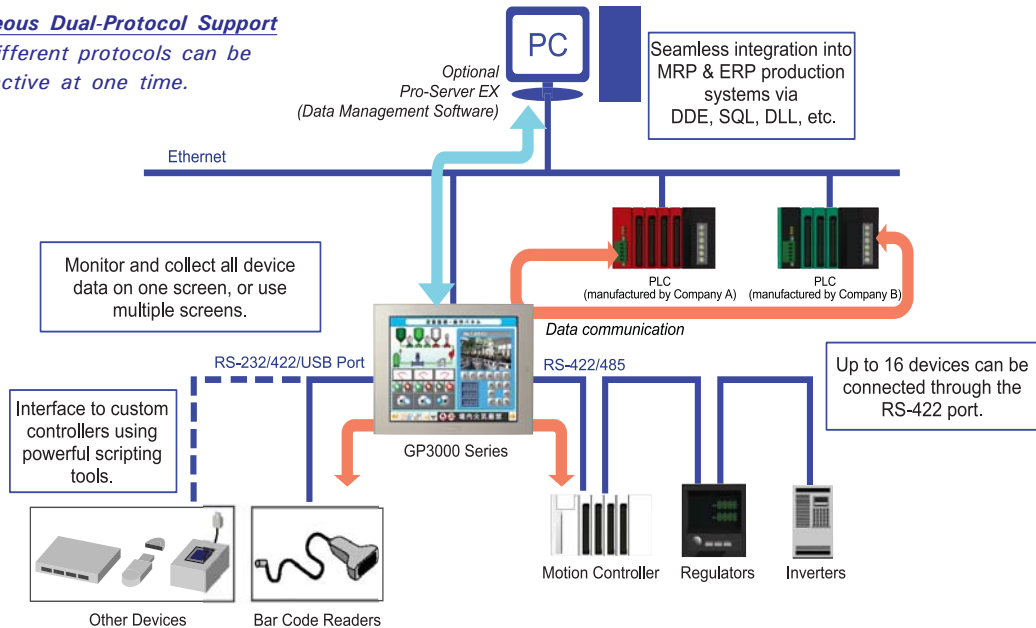

AGP3300L SPECIFICATIONS

FUNCTIONAL SPECIFICATIONS

Model	AGP3300-L1-D24	
Display	Type	Monochrome LCD
	Colors	Black and White (16 shades)
	Backlight	CCFL Service life: 58,000 hrs. or more at 25°C (77°F) and 24 hrs. operation
	Resolution	320 x 240 pixels
	Brightness & Contrast Controls	8 levels of adjustment available via touch panel
Memory	Touch Panel	Resistive film analog 1024 x 1024 resolution
	Application	6 MB FEPRM
Interfaces	Data Backup	320KB SRAM
	Serial (COM 1) Interface	RS-232C/422/485 configurable, 9 pin D-sub plug, Data Transmission Speed: 2400 to 115.2 kbps
	Serial (COM 2) Interface	RS-422/485, 9 pin D-sub socket, Data Transmission Speed: 2400 to 115.2 kbps (MPI Direct 187.5 kbps)
	Ethernet Interface	Ethernet IEEE802.3, 10BASE-T/100BASE-TX, modular jack connector (RJ-45)
	USB Interface	1 Port USB1.1 Host I/F, USB TYPE-A connector
	CF Card Interface	1 slot CompactFlash™, TYPE II

GENERAL SPECIFICATIONS

Electrical	Rated Voltage	24V DC
	Rated Voltage Range	19.2V DC to 28.8V DC
	Power Consumption	26W or less
Environmental	Ambient Operating Temp.	0°C (32°F) to 50°C (122°F)
	Storage Temperature	-20°C (-4°F) to 60°C (140°F)
	Storage Humidity	10%RH to 90%RH (non-condensing, wet bulb temperature: 39°C (102°F) or less)
	Altitude Operation	800hPa to 1114hPa (2000 meters or lower)
Structural	Vibration & Shock Resistance	IEC61131-2 compliant. 5Hz to 9Hz single amplitude 3.5mm, 9Hz to 150Hz fixed acceleration 9.8m/s ² , X,Y, Z directions for 10 times (80min.)
	Ratings	Equivalent to IP65f, Nema #250 Type 4x/13 (Equivalent to NEMA 12 with the addition of "Oil or Coolant Spraying and Splashing")
	Certifications	CE, CSA, UL listed CI 1 Div 2
	External Dimensions	W167.4mm[6.59in.] x H135mm [5.31in.] x D59.5mm [2.34in.]
	Weight	1.0kg (2.2lb) or less

CUT-OUT COMPATIBILITY

16 Years of Cut-Out Compatibility



Old model

Panel cutout dimensions

AGP3000 model
"Drop-in"



Size (mm)	156x123.5 mm	
Series		
GP77R Series	GP377R Series	
GP2000 Series	GP2300/ GP2301 Series	
GP3000 Series	GP-3300 Series	

SOFTWARE COMPATIBILITY



POWERED BY:

Screen Editor

GP-Pro EX

HMI Development Software

ORDERING INFORMATION

ORDER NUMBER	DESCRIPTION
AGP3300-L1-D24	5.7" Monochrome QVGA, USB, Ethernet, Serial HMI, 24VDC

OPTIONAL ACCESSORIES

HMI-CAB-ETH	Ethernet Crossover Cable: HMI to PLC Ethernet port or to program HMI
CA3-USBCB-01	USB download cable, PC USB port to AGP USB port
CA3-DFS6-01	Overlay Screen protection sheet (5 sheets/pack)

PLC Cables & Accessories See AGP3000 Connectivity Document

Ycom Automation
Ph: 734-429-4971
Fax: 734-429-1010
<http://www.ycom.com>

Customer Support Hotline:
734-944-0482



© 2006 Ycom Automation, LLC. Specifications may change without notice.
Ycom Automation is a trademark of Ycom Automation. Other brand or product names are the property of their respective owners.