

Pro-face

Human Machine Interface

Touch Panel

Information Integration

Beautiful Graphics

Control Functions



GLC2600T

GLC2500T

GLC2400T

GLC2300T

GLC2300L



ISO9001
JQA-1367

Graphic Logic Controller

GLC

2000 SERIES

Pro-face

GLC 2000 SERIES

The next-generation 1-box solution combining HMI and control functions for a wide range of systems.



- 12.1 inch
- TFT Color
- 800 x 600 pixels
- 256 Colors
- 4MB FEPROM
- 256KB SRAM
- 128KB Program Memory
- 64KB Variable Data Memory*
- 2CH Flex Network Master I/F
- COM1 (RS-232C/RS-422)
- COM2 (RS-232C)
- Ethernet
- CF Card
- Sound Interface
- Printer Interface, Narrow-pitch D-sub
- Optional Video

*Models with revisions prior to number 1 are 32 KB

GLC2600T

GLC2600-TC41-200V   
 GLC2600-TC41-24V   



- 10.4 inch
- TFT Color
- 640 x 480 pixels
- 256 Colors
- 4MB FEPROM
- 256KB SRAM
- 128KB Program Memory
- 64KB Variable Data Memory*
- 2CH Flex Network Master I/F
- COM1 (RS-232C/RS-422)
- COM2 (RS-232C)
- Ethernet
- CF Card
- Sound Interface
- Printer Interface, Narrow-pitch D-sub
- Optional Video

GLC2500T

GLC2500-TC41-200V   
 GLC2500-TC41-24V   



- 7.4 inch
- TFT Color
- 640 x 480 pixels
- 256 Colors
- 4MB FEPROM
- 256KB SRAM
- 128KB Program Memory
- 64KB Variable Data Memory*
- 2CH Flex Network Master I/F
- COM1 (RS-232C/RS-422)
- COM2 (RS-232C)
- Ethernet
- CF Card
- Sound Interface
- Printer Interface, Narrow-pitch D-sub

*Models with revisions prior to number 1 are 32 KB

GLC2400T

GLC2400-TC41-24V   



- 5.7 inch
- TFT Color
- 320 x 240 pixels
- 256 Colors
- 2MB FEPROM
- 256KB SRAM
- 128KB Program Memory
- 64KB Variable Data Memory*
- 2CH Flex Network Master I/F
- COM1 (RS-232C/RS-422)
- COM2 (RS-232C)
- Ethernet
- CF Card

GLC2300T

GLC2300-TC41-24V   



- 5.7 inch
- Monochrome LCD
- 320 x 240 pixels
- Black & White, Gray Scale
- 2MB FEPROM
- 256KB SRAM
- 128KB Program Memory
- 64KB Variable Data Memory*
- 2CH Flex Network Master I/F
- COM1 (RS-232C/RS-422)
- COM2 (RS-232C)
- Ethernet
- CF Card

GLC2300L

GLC2300-LG41-24V   

Aluminum body for superb cooling and dust resistance.

GLC 2600 Series

Adding the Video-mix Unit allows simultaneous video/PC display on the easy-viewing 12.1-inch screen of the top GLC model.

TFT Color

12.1 inch

800 x 600 Pixels



GLC2600T

SYSTEM DESIGN

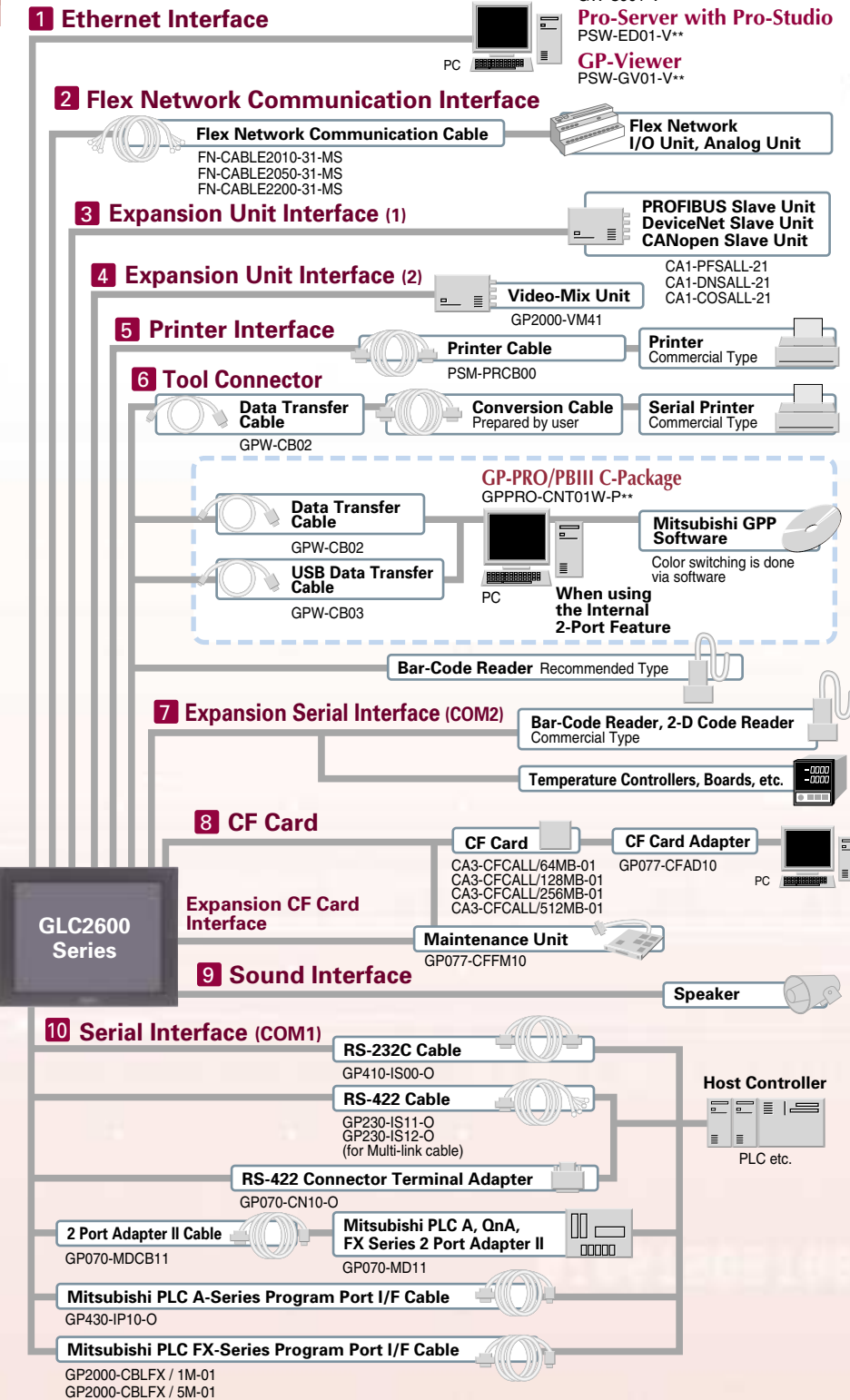

INTERFACES

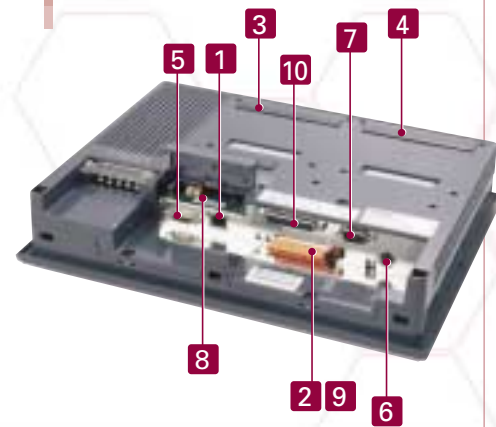

EXTERNAL DIMENSIONS

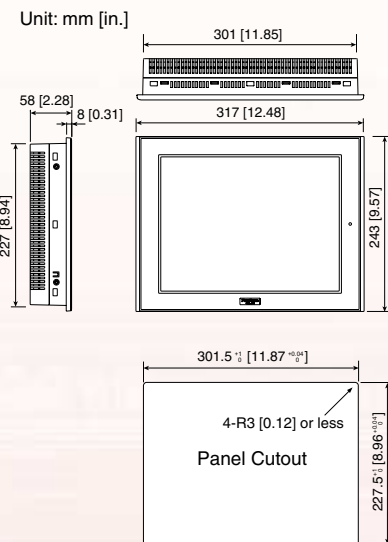

FUNCTIONAL SPECIFICATIONS

Model	GLC2600-TC41-200V/GLC2600-TC41-24V
Display Type	TFT Color LCD
Display Colors	256 colors, No blink/64 colors, 3-speed blink (Color switching is done via software)*1
Backlight	CCFL (Service life: 50,000 hrs. at 25°C and 24 hrs. operation) User replaceable.
Display Resolution	800 x 600 pixels
Effective Display Area	W246.0mm [9.69in.] x H184.5mm [7.27in.]
Brightness Control	4 levels of adjustment available via touch panel
Language Fonts	ASCII: (Code page 850) Alphanumeric (including European characters) Chinese: (GB2312-80 codes) simplified Chinese fonts Japanese: ANK-158, Kanji: 6962 (JIS Standards 1 and 2) Korean: (KSC5601-1992 codes) Hangeul fonts Taiwanese: (Big 5 codes) traditional Chinese fonts
Text	8 x 8 dots: 100 Char. x 75 rows 8 x 16 dots: 100 Char. x 37 rows 16 x 16 dots: 50 Char. x 37 rows 32 x 32 dots: 25 Char. x 18 rows
Character Sizes*2	8 x 8 dot font, 8 x 16 dot font, 16 x 16 dot font, 32 x 32 dot font
Font Sizes	Width: 1-8 times expandable / Height: 1/2", 1-8 times expandable
Touch Panel Resolution	40 x 30 keys / screen - 1 or 2 point touch
Application	4MB FLASH EPROM (Approx. 1280 screens at 3.2KB/screen)
Data Backup	256KB SRAM - uses a lithium battery*5
Program Area	128KB FLASH EPROM
Variable Area	64KB SRAM*6 - uses a lithium battery*5
Serial Interface (COM1)	Asynchronous Transmission: RS-232C/RS-422 Data Length: 7 or 8 bits Stop Bit: 1 or 2 bits Parity: None, Odd or Even Data Transmission Speed: 2,400bps to 115.2kbps (MPI: 187.5kbps)*7
Expansion Serial Interface (COM2)	Asynchronous Transmission: RS-232C Data Length: 7 or 8 bits Stop Bit: 1 or 2 bits Parity: None, Odd or Even Data Transmission Speed: 2,400 bps to 38.4kbps
Ethernet Interface	IEEE802.3 10BASE-T
Tool Connector Interface	Asynchronous TTL level nonprocedural command I/F <During screen file development> Used for transferring data to and from the GLC application software and the GLC. Used for data transfer with the 2-Port feature. <During Logic Program Development> Used for transferring data to and from the Logic Program Development software and the GLC. <During RUN Mode> Used for a variety of devices, including bar-code readers.
CF Card Interface	1 slot (CompactFlash™)
Expansion CF Card Interface	CF Card Front Maintenance Unit Connector
Printer Interface	Compatible with NEC PC-PR201/PL, EPSON ESC/P24-J84(C), HP Laser Jet PCL 4 command, EPSON PM/Stylus (6-color ink), EPSON Stylus (4-color) compatible printers*8
External Reset Input I/F	Remote Reset Input: 1 point Input Voltage: DC24V±10%, Input Current: 4mA (TYP), Min. Input Pulse Width: 2ms Operating Voltage: (When ON) Min. DC21.2V, (When OFF) Max. DC3V Isolation Method: Photo-coupler Isolation
Expansion Unit Interface	Video-Mix Unit
Communication Style	1: N
Connection Format	Multi Drop Connection
Communication Range	200m/CH at 6Mbps, 100m/CH at 12Mbps
Communication Format	Cyclic Data Transfer, Half-duplex
Communication Speed	6Mbps, 12Mbps
Communication I/F	Differential method, Pulse Transformer Insulation method
Error Check	Format Test, Bit Test, CRC-12 Test
Max. Number of Nodes	63 (1008 I/O points)
Sound Output	External Speaker Connection (Terminal Block) Monaural 1CH Speaker Output 70mW (Rated Load: 8Ω, Frequency: 1kHz) Sound Line Out Output 2.7Vp-p (Rated Load: 10kΩ) Recommended Wire: AWG#28 to #16

*1 Changing the colors setting to "256 colors" will disable the blink feature on all screens in your project. If you wish to use the blink feature, do not change this setting to "256 colors".

*2 The font size varies depending on the selected language and expansion ratio.

*3 Only available when using "1/2 2 Byte Character" settings via software. (Only Japanese, Chinese, Taiwanese, and Korean characters)

*4 128 KB of SRAM is reserved for the Online Editor.

*5 A Lithium battery's lifetime is:
• 10 years when the battery's ambient temperature is 40°C or less.
• 4.1 years when the battery's ambient temperature is 50°C or less.
• 1.5 years when the battery's ambient temperature is 60°C or less.
When used for backup:
• Approximately 60 days, with a fully charged battery.
• Approximately 6 days, with a half-charged battery.

*6 Models with revisions prior to number 1 are 32 KB.

*7 SIEMENS SIMATIC S7-200/300/400 series (MPI port only). Please contact your Pro-face sales representative for supported models and other details.

*8 Printers with only Windows drivers cannot be used. However, certain types of printers with both Windows® and DOS® drivers can be used. For details, contact your local GLC distributor.

GENERAL SPECIFICATIONS

Model	GLC2600-TC41-200V	GLC2600-TC41-24V
Rated Voltage	AC100V to AC240V	DC24V
Rated Voltage Range	AC85V to AC265V	DC19.2V to DC28.8V
Power Consumption	50VA or less (ACIN100V) 85VA or less (ACIN240V)	50W or less
Allowable Voltage Drop	20ms or less	10ms or less
Voltage Endurance	AC1500V 20mA for 1 minute (between charging and FG terminals)	AC1000V 20mA for 1 minute (between charging and FG terminals)
Insulation Resistance	10MΩ or higher at DC500V (between charging and FG terminals)	
Ambient Operating Temperature	0°C to +50°C*1	
Storage Temperature	-20°C to +60°C	
Operating Humidity	10%RH to 90%RH (Non-condensing, wet bulb temperature: 39°C or less)	
Storage Humidity	10%RH to 90%RH (Non-condensing, wet bulb temperature: 39°C or less)	
Vibration Resistance	IEC61131-2 (JIS B 3501) compliant When vibration is NOT continuous: 10Hz to 57Hz 0.075mm, 57Hz to 150Hz 9.8m/s² When vibration is continuous: 10Hz to 57Hz 0.035mm, 57Hz to 150Hz 4.9m/s² X, Y, Z directions for 10 times (80min.)	
Noise Immunity (via noise simulator)	Noise Voltage: 1500Vp-p, Pulse Duration: 1 μs Arise Time: 1ns	
Electrostatic Discharge Immunity	Contact Discharge Method 6kV (complies with IEC 61000-4-2 Level 3)	
Air Purity (Dust)	0.1mg/m³ or less (non-conductive levels)	
Atmospheric Endurance	800hPa to 1,114hPa (2,000 meters or lower)	
Corrosive Gasses	Free of corrosive gasses	
Grounding	100Ω or less, or your country's applicable standard*2	
Ratings	Equivalent to IP65f (JEM1030)*3, and NEMA#250 Type4 X/12 (limited to the front face after installation in a panel)	
Certifications	EN55011 Class A, EN61000-3-2, EN61000-3-3, EN61000-6-2, EN60950, UL 1604 EN55011 Class A, EN61000-6-2, UL 508, UL 1604	
External Dimensions	W317mm [12.48in.] x H243mm [9.57in.] x D58mm [2.28in.] (main unit only)	
Weight	3.5kg (7.72lb) or less (main unit only)	
Cooling Method	Natural air circulation	

*1 Operating temperature reflects the panel external (GLC unit front face) and panel internal temperatures.

*2 Grounding requirements differ from country to country. Be sure to confirm your work environment requirements prior to installation. For more information, please contact your GLC distributor.

*3 The degree of protection provided by these products is equivalent to IP65f, however their performance cannot be guaranteed for every environment. Be sure to confirm your work environment requirements prior to installation.

GLC 2500 Series

10.4-inch TFT color LCD with two power supplies to choose from.
Standard models with a wide range of interfaces.

TFT Color

10.4 inch

640 x 480 Pixels



GLC2500T

SYSTEM DESIGN

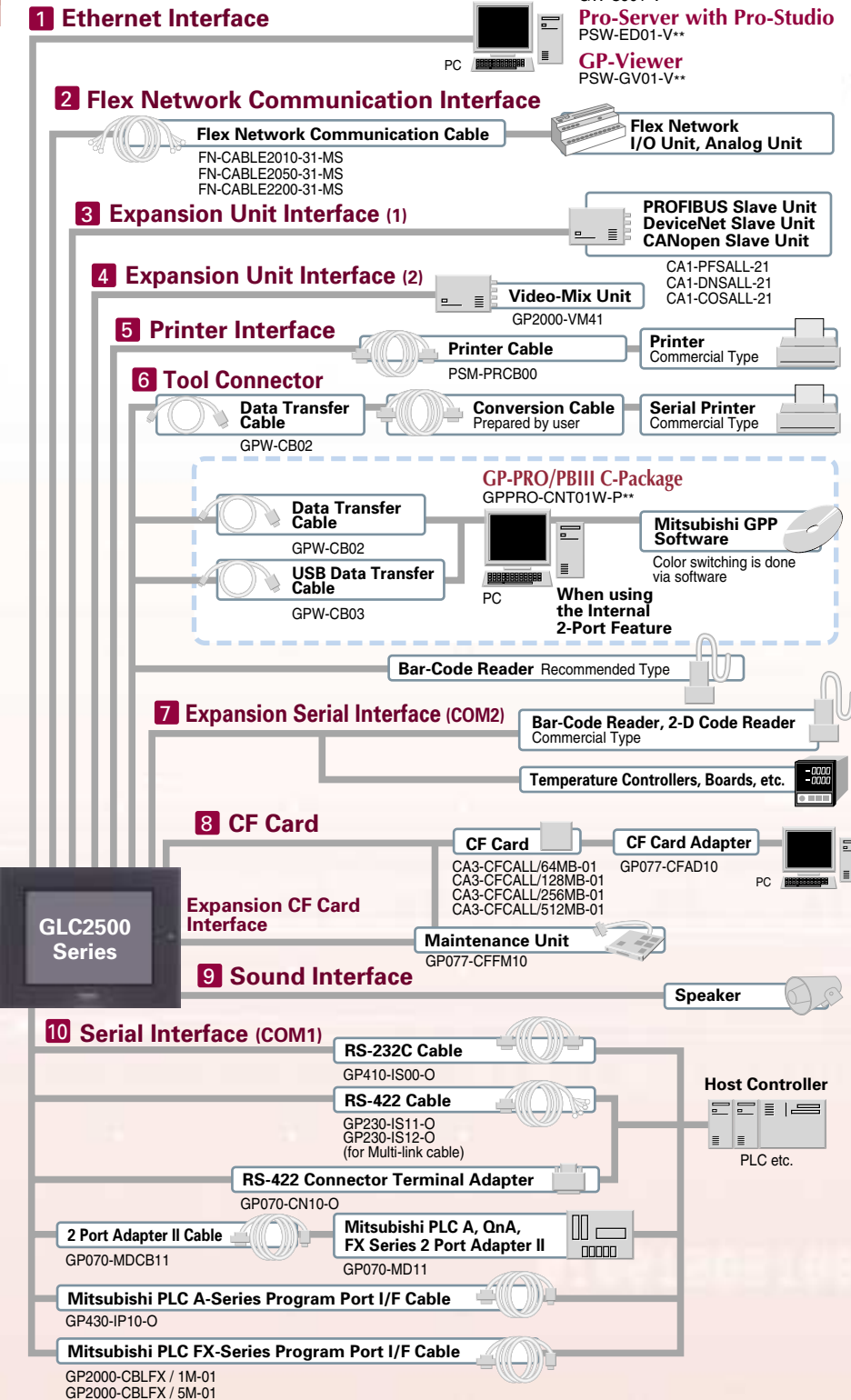

INTERFACES

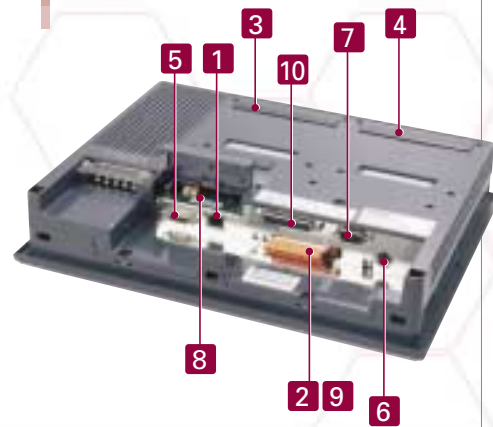

EXTERNAL DIMENSIONS

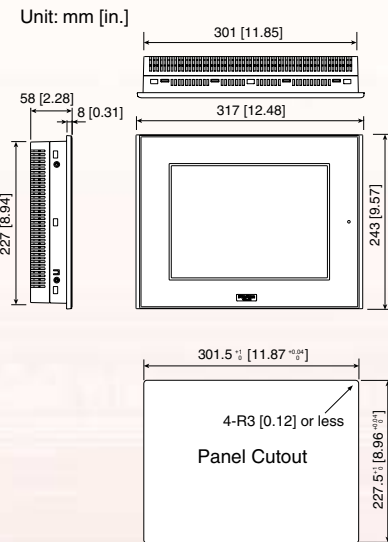

FUNCTIONAL SPECIFICATIONS

Model	GLC2500-TC41-200V/GLC2500-TC41-24V
Display Type	TFT Color LCD
Display Colors	256 colors, No blink/64 colors, 3-speed blink (Color switching is done via software)*1
Backlight	CCFL (Service life: 50,000 hrs. at 25°C and 24 hrs. operation) User replaceable.
Display Resolution	640 x 480 pixels
Effective Display Area	W211.2mm [8.31in.] x H158.4mm [6.24in.]
Brightness Control	4 levels of adjustment available via touch panel
Language Fonts	ASCII: (Code page 850) Alphanumeric (including European characters) Chinese: (GB2312-80 codes) simplified Chinese fonts Japanese: ANK 158, Kanji; 6962 (JIS Standards 1 and 2) Korean: (KSC5601-1992 codes) Hangul fonts Taiwanese: (Big 5 codes) traditional Chinese fonts
Text	8 x 8 dots: 80 Char. x 60 rows 8 x 16 dots: 80 Char. x 30 rows 16 x 16 dots: 40 Char. x 30 rows 32 x 32 dots: 20 Char. x 15 rows
Character Sizes*2	8 x 8 dot font, 8 x 16 dot font, 16 x 16 dot font, 32 x 32 dot font
Font Sizes	Width: 1-8 times expandable / Height: 1/2", 1-8 times expandable
Touch Panel Resolution	32 x 24 keys / screen - 1 or 2 point touch
Application	4MB FLASH EPROM (Approx. 1280 screens at 3.2KB/screen)
Data Backup	256KB SRAM - uses a lithium battery*5
Program Area	128KB FLASH EPROM
Variable Area	64KB SRAM - uses a lithium battery*5
Serial Interface (COM1)	Asynchronous Transmission: RS-232C/RS-422 Data Length: 7 or 8 bits Stop Bit: 1 or 2 bits Parity: None, Odd or Even Data Transmission Speed: 2,400bps to 115.2kbps (MPI: 187.5kbps)*6
Expansion Serial Interface (COM2)	Asynchronous Transmission: RS-232C Data Length: 7 or 8 bits Stop Bit: 1 or 2 bits Parity: None, Odd or Even Data Transmission Speed: 2,400 bps to 38.4kbps
Ethernet Interface	IEEE802.3 10BASE-T
Tool Connector Interface	Asynchronous TTL level nonprocedural command I/F <During screen file development> Used for transferring data to and from the GLC application software and the GLC. Used for data transfer with the 2-Port feature. <During Logic Program Development> Used for transferring data to and from the Logic Program Development software and the GLC. <During RUN Mode> Used for a variety of devices, including bar-code readers.
CF Card Interface	1 slot (CompactFlash™)
Expansion CF Card Interface	CF Card Front Maintenance Unit Connector
Printer Interface	Compatible with NEC PC-PR201/PL, EPSON ESC/P24-J84(C), HP Laser Jet PCL 4 command, EPSON PM/Stylus (6-color ink), EPSON Stylus (4-color) compatible printers*7
External Reset Input I/F	Remote Reset Input: 1 point Input Voltage: DC24V±10%, Input Current: 4mA (TYP), Min. Input Pulse Width: 2ms Operating Voltage: (When ON) Min. DC21.2V, (When OFF) Max. DC3V Isolation Method: Photo-coupler Isolation
Expansion Unit Interface	Video-Mix Unit
Communication Style	1: N
Connection Format	Multi Drop Connection
Communication Range	200m/CH at 6Mbps, 100m/CH at 12Mbps
Communication Format	Cyclic Data Transfer, Half-duplex
Communication Speed	6Mbps, 12Mbps
Communication I/F	Differential method, Pulse Transformer Insulation method
Error Check	Format Test, Bit Test, CRC-12 Test
Max. Number of Nodes	63 (1008 I/O points)
Sound Output	External Speaker Connection (Terminal Block) Monaural 1CH Speaker Output 70mW (Rated Load: 8Ω, Frequency: 1kHz) Sound Line Out Output 2.7Vp-p (Rated Load: 10kΩ) Recommended Wire: AWG#28 to #16

*1 Changing the colors setting to "256 colors" will disable the blink feature on all screens in your project. If you wish to use the blink feature, do not change this setting to "256 colors".

*2 The font size varies depending on the selected language and expansion ratio.

*3 Only available when using "1/2 Byte Character" settings via software. (Only Japanese, Chinese, Taiwanese, and Korean characters)

*4 128 KB of SRAM is reserved for the Online Editor.

*5 A Lithium battery's lifetime is:

- 10 years when the battery's ambient temperature is 40°C or less.
- 4.1 years when the battery's ambient temperature is 50°C or less.
- 1.5 years when the battery's ambient temperature is 60°C or less.

When used for backup:

- Approximately 60 days, with a fully charged battery.
- Approximately 6 days, with a half-charged battery.

*6 SIEMENS SIMATIC S7-200/300/400 series (MPI port only). Please contact your Pro-face sales representative for supported models and other details.

*7 Printers with only Windows drivers cannot be used. However, certain types of printers with both Windows® and DOS® drivers can be used. For details, contact your local GLC distributor.

GENERAL SPECIFICATIONS

Model	GLC2500-TC41-200V	GLC2500-TC41-24V
Rated Voltage	AC100V to AC240V	DC24V
Rated Voltage Range	AC85V to AC265V	DC19.2V to DC28.8V
Power Consumption	50VA or less (ACIN100V) 85VA or less (ACIN240V)	50W or less
Allowable Voltage Drop	20ms or less	10ms or less
Voltage Endurance	AC1500V 20mA for 1 minute (between charging and FG terminals)	AC1000V 20mA for 1 minute (between charging and FG terminals)
Insulation Resistance	10MΩ or higher at DC500V (between charging and FG terminals)	
Ambient Operating Temperature	0°C to +50°C	
Storage Temperature	-20°C to +60°C	
Operating Humidity	10%RH to 90%RH (Non-condensing, wet bulb temperature: 39°C or less)	
Storage Humidity	10%RH to 90%RH (Non-condensing, wet bulb temperature: 39°C or less)	
Vibration Resistance	IEC61131-2 (JIS B 3501) compliant When vibration is NOT continuous: 10Hz to 57Hz 0.075mm, 57Hz to 150Hz 9.8m/s² When vibration is continuous: 10Hz to 57Hz 0.035mm, 57Hz to 150Hz 4.9m/s² X, Y, Z directions for 10 times (80min.)	
Noise Immunity (via noise simulator)	Noise Voltage: 1500Vp-p, Pulse Duration: 1 μs Arise Time: 1ns	
Electrostatic Discharge Immunity	Contact Discharge Method 6kV (complies with IEC 61000-4-2 Level 3)	
Air Purity (Dust)	0.1mg/m³ or less (non-conductive levels)	
Atmospheric Endurance	800hPa to 1,114hPa (2,000 meters or lower)	
Corrosive Gasses	Free of corrosive gases	
Grounding	100Ω or less, or your country's applicable standard*1	
Ratings	Equivalent to IP65f (JEM1030)*2, and NEMA#250 Type4 X/12 (limited to the front face after installation in a panel)	
Certifications	EN55011 Class A, EN61000-3-2, EN61000-3-3, EN61000-6-2, EN60950, UL1604 EN55011 Class A, EN61000-6-2, UL 508, UL 1604	
External Dimensions	W317mm [12.48in.] x H243mm [9.57in.] x D58mm [2.28in.] (main unit only)	
Weight	3.5kg (7.72lb) or less (main unit only)	
Cooling Method	Natural air circulation	

*1 Grounding requirements differ from country to country. Be sure to confirm your work environment requirements prior to installation. For more information, please contact your GLC distributor.

*2 The degree of protection provided by these products is equivalent to IP65f, however their performance cannot be guaranteed for every environment. Be sure to confirm your work environment requirements prior to installation.

GLC 2400 Series

The 7.4-inch size with 640 x 480 pixels resolution meets a variety of applications, from large-size equipment to panel integration.

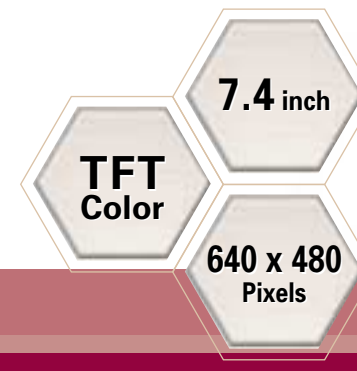

GLC2400T

SYSTEM DESIGN

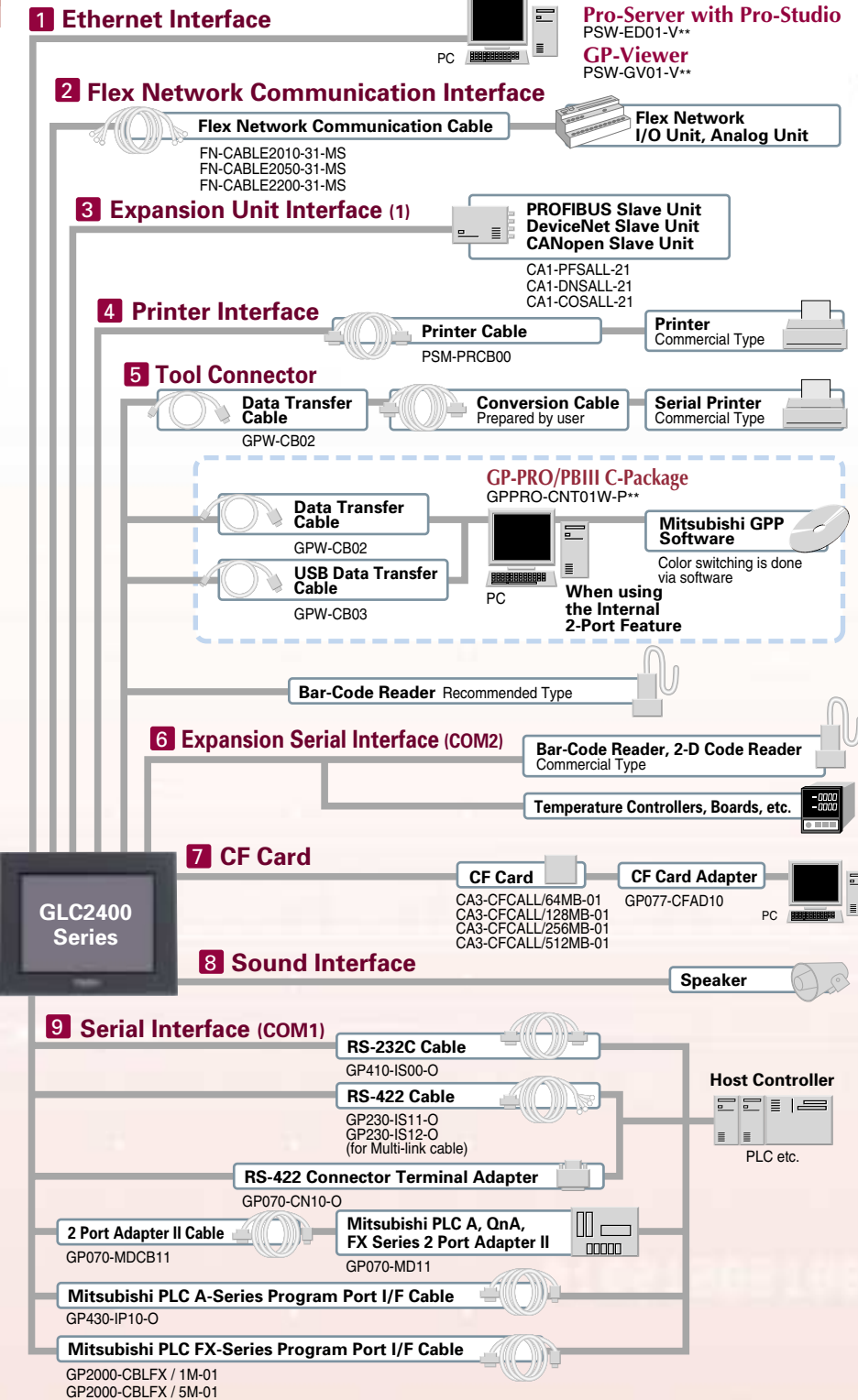

INTERFACES

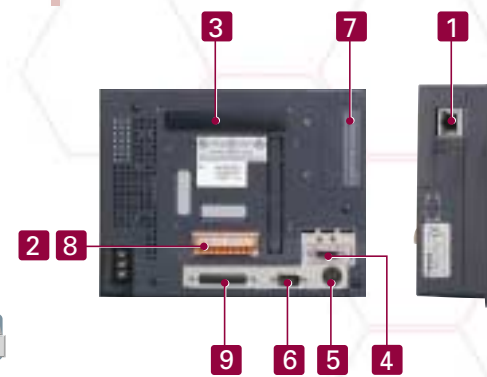

EXTERNAL DIMENSIONS

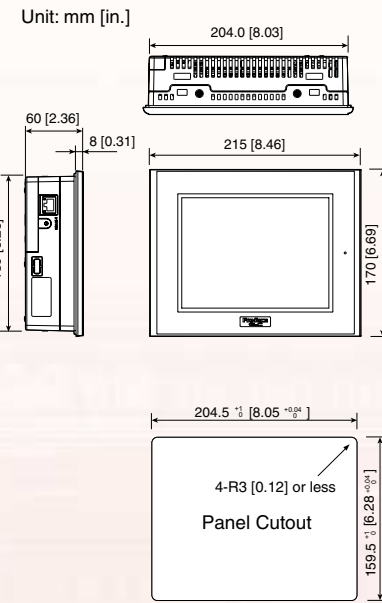

FUNCTIONAL SPECIFICATIONS

Model	GLC2400-TC41-24V
Display Type	TFT Color LCD
Display Colors	256 colors, No blink/64 colors, 3-speed blink (Color switching is done via software)*1
Backlight	CCFL (Service life: 50,000 hrs. at 25°C and 24 hrs. operation) User replaceable.
Display Resolution	640 x 480 pixels
Effective Display Area	W149.8mm [5.90in.] x H112.3mm [4.42in.]
Brightness Control	4 levels of adjustment available via touch panel
Language Fonts	ASCII: (Code page 850) Alphanumeric (including European characters) Chinese: (GB2312-80 codes) simplified Chinese fonts Japanese: ANK-158, Kanji: 6952 (JIS Standards 1 and 2) Korean: (KSC5601-1992 codes) Hangul fonts Taiwanese: (Big 5 codes) traditional Chinese fonts
Text	8 x 8 dots 8 x 16 dots 16 x 16 dots 32 x 32 dots
Character Sizes*2	80 Char. x 60 rows 80 Char. x 30 rows 40 Char. x 30 rows 20 Char. x 15 rows
Font Sizes	8 x 8 dot font, 8 x 16 dot font, 16 x 16 dot font, 32 x 32 dot font Width: 1-8 times expandable / Height: 1/2-3, 1-8 times expandable
Touch Panel Resolution	32 x 24 keys / screen - 1 or 2 point touch
Application	4MB FLASH EPROM (Approx. 1280 screens at 3.2KB/screen)
Data Backup	256KB SRAM - uses a lithium battery*5
Program Area	128KB FLASH EPROM
Variable Area	64KB SRAM*6 - uses a lithium battery*5
Serial Interface (COM1)	Asynchronous Transmission : RS-232C/RS-422 Data Length: 7 or 8 bits Stop Bit: 1 or 2 bits Parity: None, Odd or Even Data Transmission Speed: 2,400bps to 115.2kbps (MPI: 187.5kbps)*7
Expansion Serial Interface (COM2)	Asynchronous Transmission : RS-232C Data Length: 7 or 8 bits Stop Bit: 1 or 2 bits Parity: None, Odd or Even Data Transmission Speed: 2,400 bps to 38.4kbps
Ethernet Interface	IEEE802.3 10BASE-T
Tool Connector Interface	Asynchronous TTL level nonprocedural command I/F <During screen file development> Used for transferring data to and from the GLC application software and the GLC. Used for data transfer with the 2-Port feature. <During Logic Program Development> Used for transferring data to and from the Logic Program Development software and the GLC. <During RUN Mode> Used for a variety of devices, including bar-code readers.
CF Card Interface	1 slot (CompactFlash™)
Expansion CF Card Interface	-
Printer Interface	Compatible with NEC PC-PR201/PL, EPSON ESC/P24-J84(C), HP Laser Jet PCL 4 command, EPSON PM/Stylus (6-color ink), EPSON Stylus (4-color) compatible printers*8
External Reset Input I/F	Remote Reset Input: 1 point Input Voltage: DC24V±10%, Input Current: 4mA (TYP), Min. Input Pulse Width: 2ms Operating Voltage: (When ON) Min. DC21.2V, (When OFF) Max. DC3V Isolation Method: Photo-coupler Isolation
Communication Style	1: N
Connection Format	Multi Drop Connection
Communication Range	200m/CH at 6Mbps, 100m/CH at 12Mbps
Communication Format	Cyclic Data Transfer, Half-duplex
Communication Speed	6Mbps, 12Mbps
Communication I/F	Differential method, Pulse Transformer insulation method
Error Check	Format Test, Bit Test, CRC-12 Test
Max. Number of Nodes	63 (1008 I/O points)
Sound Output	External Speaker Connection (Terminal Block) Monaural 1CH Speaker Output 70mW (Rated Load: 8Ω, Frequency: 1kHz) Sound Line Out Output 2.7Vp-p (Rated Load: 10kΩ) Recommended Wire: AWG#28 to #16

*1 Changing the colors setting to "256 colors" will disable the blink feature on all screens in your project. If you wish to use the blink feature, do not change this setting to "256 colors".

*2 The font size varies depending on the selected language and expansion ratio.

*3 Only available when using "1/2 Byte Character" settings via software. (Only Japanese, Chinese, Taiwanese, and Korean characters)

*4 128 KB of SRAM is reserved for the Online Editor.

*5 A Lithium battery's lifetime is:
 • 10 years when the battery's ambient temperature is 40°C or less.
 • 4.1 years when the battery's ambient temperature is 50°C or less.
 • 1.5 years when the battery's ambient temperature is 60°C or less.
 When used for backup:
 • Approximately 60 days, with a fully charged battery.
 • Approximately 6 days, with a half-charged battery.

*6 Models with revisions prior to number 1 are 32 KB.

*7 SIEMENS SIMATIC S7-200/300/400 series (MPI port only). Please contact your Pro-face sales representative for supported models and other details.

*8 Printers with only Windows drivers cannot be used. However, certain types of printers with both Windows® and DOS® drivers can be used. For details, contact your local GLC distributor.

GENERAL SPECIFICATIONS

Model	GLC2400-TC41-24V
Rated Voltage	DC24V
Rated Voltage Range	DC19.2V to DC28.8V
Power Consumption	28W or less
Allowable Voltage Drop	10ms or less
Voltage Endurance	AC1000V 20mA for 1 minute (between charging and FG terminals)
Insulation Resistance	10MΩ or higher at DC500V (between charging and FG terminals)
Ambient Operating Temperature	0°C to +50°C
Storage Temperature	-20°C to +60°C
Operating Humidity	10%RH to 90%RH (Non-condensing, wet bulb temperature: 39°C or less)
Storage Humidity	10%RH to 90%RH (Non-condensing, wet bulb temperature: 39°C or less)
Vibration Resistance	IEC61131-2 (JIS B 3501) compliant When vibration is NOT continuous: 10Hz to 57Hz 0.075mm, 57Hz to 150Hz 9.8m/s² When vibration is continuous: 10Hz to 57Hz 0.035mm, 57Hz to 150Hz 4.9m/s² X, Y, Z directions for 10 times (80min.)
Noise Immunity (via noise simulator)	Noise Voltage: 1500Vp-p, Pulse Duration: 1 μs Arise Time: 1ns
Electrostatic Discharge Immunity	Contact Discharge Method 6kV (complies with IEC 61000-4-2 Level 3)
Air Purity (Dust)	0.1mg/m³ or less (non-conductive levels)
Atmospheric Endurance	800hPa to 1,114hPa (2,000 meters or lower)
Corrosive Gasses	Free of corrosive gases
Grounding	100Ω or less, or your country's applicable standard*1
Ratings	Equivalent to IP65f (JEM1030)*2 and NEMA#250 Type4 X/12 (limited to the front face after installation in a panel)
Certifications	EN55011 Class A, EN61000-6-2, UL 508, UL 1604
External Dimensions	W215mm [8.46in.] x H170mm [6.69in.] x D60mm [2.36in.]
Weight	1.7kg (3.7lb) or less
Cooling Method	Natural air circulation

*1 Grounding requirements differ from country to country. Be sure to confirm your work environment requirements prior to installation. For more information, please contact your GLC distributor.

*2 The degree of protection provided by these products is equivalent to IP65f, however their performance cannot be guaranteed for every environment. Be sure to confirm your work environment requirements prior to installation.

GLC 2300 Series

The mid-size 5.7-inch models with network connectivity.

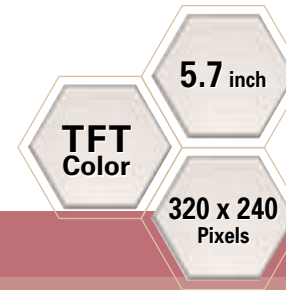

GLC2300T

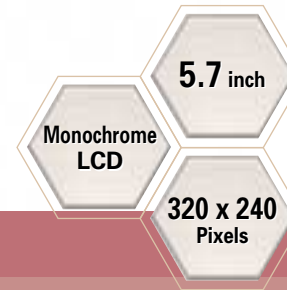

GLC2300L

SYSTEM DESIGN

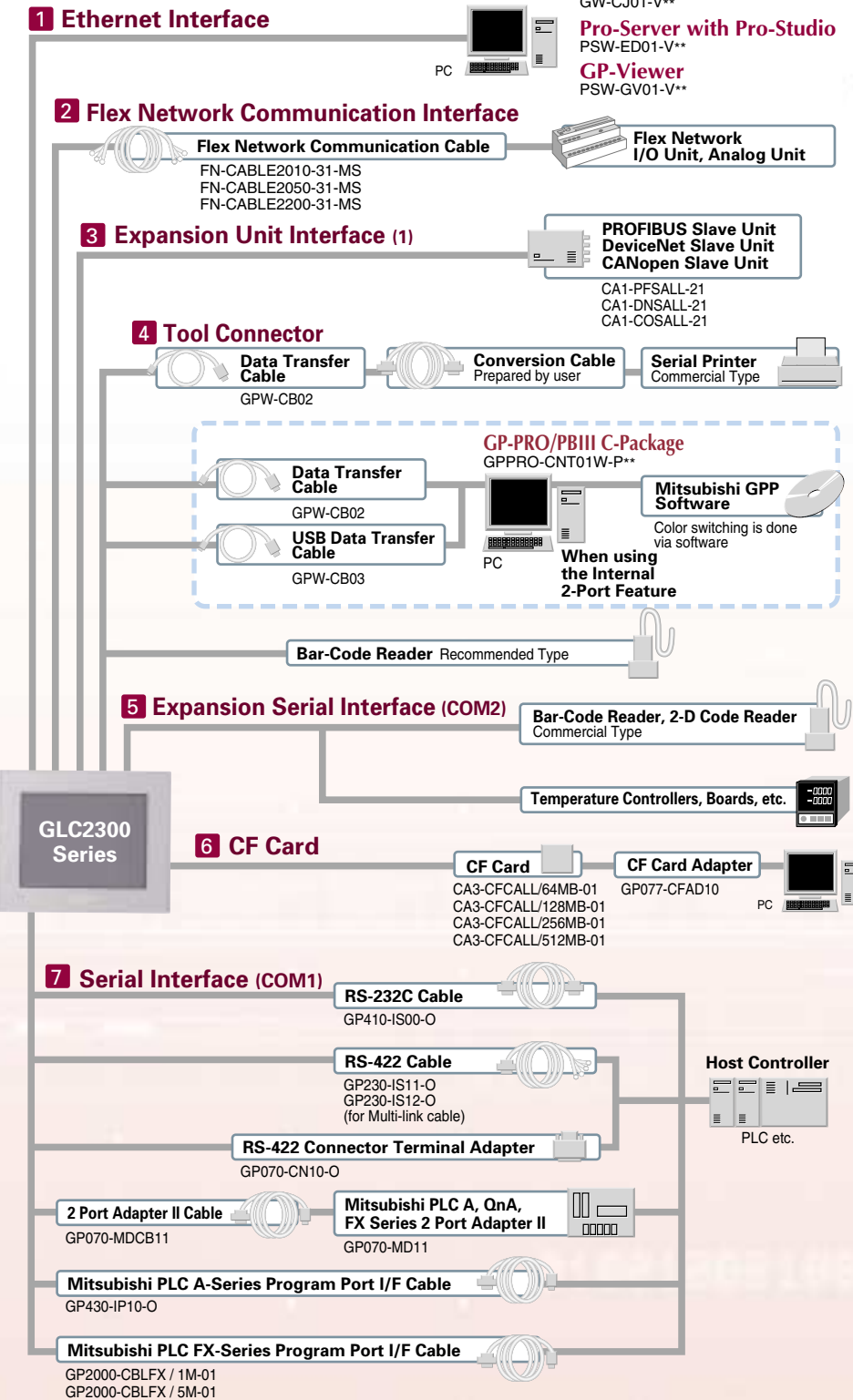

INTERFACES

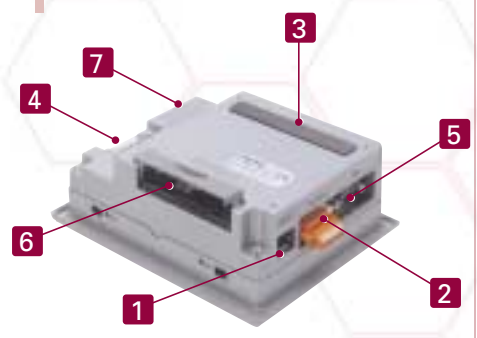

EXTERNAL DIMENSIONS

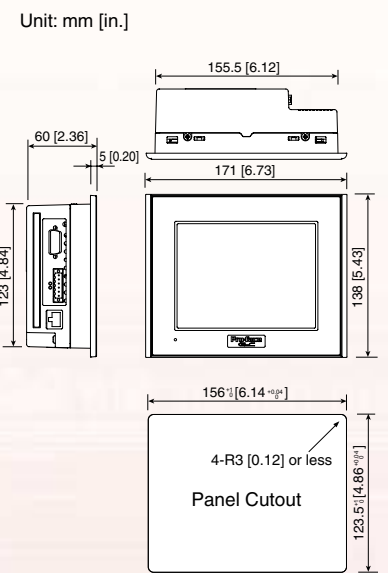

FUNCTIONAL SPECIFICATIONS

Model	GLC2300-TC41-24V	GLC2300-LG41-24V	
Display Type	TFT Color LCD	Monochrome LCD	
Display Colors	256 colors, No blink/64 colors, 3-speed blink (Color switching is done via software)*1	Black and White, 2 levels of gray/Black and White, 8 levels of gray*2 (Color switching is done via software)	
Backlight	CCFL (Service life: 50,000 hrs. or more at 25°C and 24 hrs. operation) Not user replaceable	CCFL (Service life: 50,000 hrs. or more at 25°C and 24 hrs. operation) User replaceable	
Display Resolution	320 x 240 pixels		
Effective Display Area	W115.2mm [4.54in.] x H86.4mm [3.40in.]		
Brightness Control	4 levels of adjustment available via touch panel		
Contrast Adjustment	8 levels of adjustment available via touch panel		
Language Fonts	ASCII: (Code page 850) Alphanumeric (including European characters) Chinese: (GB2312-80 codes) simplified Chinese fonts Japanese: ANK 158, Kanji: 6962 (JIS Standards 1 and 2) Korean: (KSC5601-1992 codes) Hangul fonts Taiwanese: (Big 5 codes) traditional Chinese fonts		
Text	8 x 8 dots	40 Char. x 30 rows	
	8 x 16 dots	40 Char. x 15 rows	
	16 x 16 dots	20 Char. x 15 rows	
	32 x 32 dots	10 Char. x 7 rows	
Character Sizes*3	8 x 8 dot font, 8 x 16 dot font, 16 x 16 dot font, 32 x 32 dot font		
Font Sizes	Width: 1-8 times expandable / Height: 1/2*4, 1-8 times expandable		
Touch Panel Resolution	16 x 12 keys / screen - 1 or 2 point touch		
Memory	Application	2MB FLASH EPROM (Approx. 640 screens at 3.2KB / screen)	
	Data Backup	256KB SRAM - uses a lithium battery*5	
	Program Area	128KB FLASH EPROM	
Variable Area	64KB SRAM - uses a lithium battery*6		
Serial Interface (COM1)	Asynchronous Transmission: RS-232C/RS-422 Data Length: 7 or 8 bits Stop Bit: 1 or 2 bits Parity: None, Odd or Even Data Transmission Speed: 2,400bps to 115.2kbps (MPI: 187.5kbps)*7		
	Expansion Serial Interface (COM2) Asynchronous Transmission: RS-232C Data Length: 7 or 8 bits Stop Bit: 1 or 2 bits Parity: None, Odd or Even Data Transmission Speed: 2,400 bps to 38.4kbps		
	Ethernet Interface IEEE802.3 10BASE-T		
Tool Connector Interface	Asynchronous TTL level nonprocedural command I/F <During screen file development> Used for transferring data to and from the GLC application software and the GLC. Used for data transfer with the 2-Port feature. <During Logic Program Development> Used for transferring data to and from the Logic Program Development software and the GLC. <During RUN Mode> Used for a variety of devices, such as bar-code readers and serial printers.		
CF Card Interface	1 slot (CompactFlash™)		
Expansion CF Card Interface	---		
Printer Interface	---		
External Reset Input I/F	---		
Flex Network	Communication Style	1: N	
	Connection Format	Multi Drop Connection	
	Communication Range	200m/CH at 6Mbps, 100m/CH at 12Mbps	
	Communication Format	Cyclic Data Transfer, Half-duplex	
	Communication Speed	6Mbps, 12Mbps	
	Communication I/F	Differential method, Pulse Transformer Insulation method	
Error Check	Format Test, Bit Test, CRC-12 Test		
Max. Number of Nodes	63 (1008 I/O points)		
Sound Output	---		

*1 Changing the colors setting to "256 colors" will disable the blink feature on all screens in your project. If you wish to use the blink feature, do not change this setting to "256 colors".

*2 In order to set the monochrome (eight levels of gray) mode, GP-PRO/PB III for Windows Ver.6.2 or later is required. Depending on the color used, selecting MONOCHROME 8 HUES may cause the GLC unit's screen to flicker and make it difficult to distinguish colors. Confirm that all colors display as expected prior to using this mode.

*3 The font size varies depending on the selected language and expansion ratio.

*4 Only available when using "1/2 Byte Character" settings via software. (Only Japanese, Chinese, Taiwanese, and Korean characters)

*5 128 KB of SRAM is reserved for the Online Editor.

*6 A Lithium battery's lifetime is:
 • 10 years when the battery's ambient temperature is 40°C or less.
 • 4.1 years when the battery's ambient temperature is 50°C or less.
 • 1.5 years when the battery's ambient temperature is 60°C or less.
 When used for backup:
 • Approximately 60 days, with a fully charged battery.
 • Approximately 6 days, with a half-charged battery.

*7 SIEMENS SIMATIC S7-200/300/400 series (MPI port only). Please contact your Pro-face sales representative for supported models and other details.

*8 GLC2300T/L supports serial printers.

GENERAL SPECIFICATIONS

Model	GLC2300-TC41-24V	GLC2300-LG41-24V	
Electrical	Rated Voltage	DC24V	
	Rated Voltage Range	DC19.2V to DC28.8V	
	Power Consumption	22W or less	
	Allowable Voltage Drop	10ms or less	
	Voltage Endurance	AC1000V 20mA for 1 minute (between charging and FG terminals)	
	Insulation Resistance	20MΩ or higher at DC500V (between charging and FG terminals)	
	Ambient Operating Temperature	0°C to +50°C*1	
	Storage Temperature	-20°C to +60°C	
	Operating Humidity	10%RH to 90%RH (Non-condensing, wet bulb temperature:39°C or less)	
	Storage Humidity	10%RH to 90%RH (Non-condensing, wet bulb temperature:39°C or less)	
Environmental	Vibration Resistance	IEC61131-2 (JIS B 3501) compliant When vibration is NOT continuous: 10Hz to 57Hz 0.075mm, 57Hz to 150Hz 9.8m/s² When vibration is continuous: 10Hz to 57Hz 0.035mm, 57Hz to 150Hz 4.9m/s², 10 times (80min.) for each (X, Y, Z) direction	
	Noise Immunity (via noise simulator)	Noise Voltage: 1000Vp-p, Pulse Duration:1 μs Arise Time: 1ns	
	Electrostatic Discharge Immunity	Contact Discharge Method 6kV (complies with IEC 61000-4-2 Level 3)	
	Air Purity (Dust)	0.1mg/m³ or less (non-conductive levels)	
Structural	Atmospheric Endurance	800hPa to 1,114hPa (2,000 meters or lower)	
	Corrosive Gases	Free of corrosive gases	
	Grounding	100Ω or less, or your country's applicable standard*2	
	Ratings	Equivalent to IP65f (JEM1030)*3, and NEMA TYPE#250 4 X/ 12 (limited to the front face after installation in a panel)	
	Certifications	EN55022 Class A, EN50082-2, UL1604, UL60950	
	External Dimensions	W171mm [6.73in.] x H138mm [5.43in.] x D60mm [2.36in.]	
Weight	1.2kg (2.65lb) or less (main unit only)		
Cooling Method	Natural air circulation		

*1 Operating temperature refers to the panel external (GLC unit front face) and panel internal temperatures.

*2 Grounding requirements differ from country to country. Be sure to confirm your work environment requirements prior to installation. For more information, please contact your GLC distributor.

*3 The degree of protection provided by these products is equivalent to IP65f, however their performance cannot be guaranteed for every environment. Be sure to confirm your work environment requirements prior to installation.

INFORMATION Data Collection and Distribution

Information flows smoothly to and from the host PC via CF card or Ethernet, forming a highly reliable system for process control or data collection and providing reliable, assured support for management strategy building.

Easy data transfer by CF card.

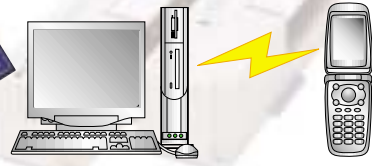

Secured and real-time data exchange with commonly used PC applications over CF card, Ethernet or the Internet.

Ethernet



SIO Expansion Unit I/F

COMMUNICATION Useful Interfaces to Meet Your Needs

Versatile interfaces support flexible expansion for a control system that meets your needs.

SIO 1ch (COM1)

To connect various controllers

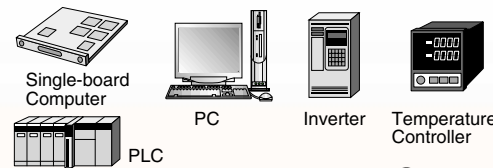

SIO 2ch (COM2)

Serial devices, such as bar code readers or two-dimensional code readers.



Expansion Unit Interface

Fieldbus slave connection*

PROFIBUS CANopen DeviceNet

* Only available from Pro-Face Europe B.V.. For further information, please contact Pro-face Europe B.V..

The Video-mix Unit enables more realistic monitoring and control

Adding the Video-mix Unit enables high-precision line surveillance and control over a single screen. Remote operation and monitoring ensures trouble free line control. Plus, the expandability of the GLC2600T/2500T with the 3-way control opens up a wealth of new production possibilities.

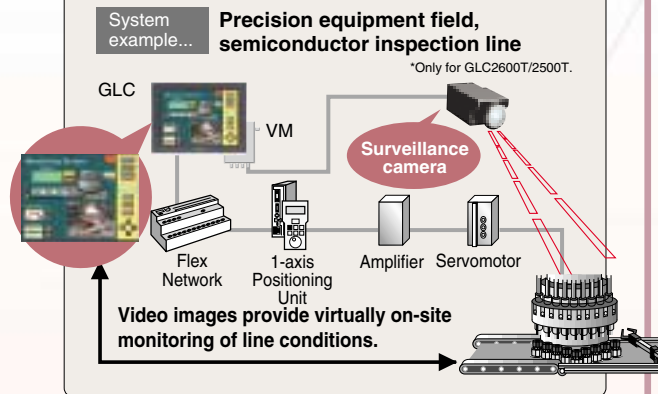

Flex Network

CONTROL Distributed I/O Terminals for up to 1008 Points

The remote I/O system contributes to more reliable, high-speed control, cutting wiring costs and labor.

Remote I/O (Flex Network) System

*For details of Flex Network, contact your local sales representative.

64-point I/O Unit

32-point Sink/Source Input, 32-point Sink-type Transistor Output

FN-XY32SKS41 (Spring Clamp Connector)



16-point I/O Units

16-point Sink/Source Input

8-point Sink/Source Input, 8-point Sink Transistor Output

16-point Sink Output

16-point Source Output

8-point Relay Output/1 Common



High-spec Units

32-point Sink/Source Input

16-point Sink/Source Input, 16-point Sink Transistor Output

16-point Sink/Source Input, 16-point Source Transistor Output

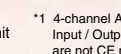
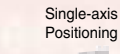
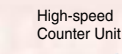
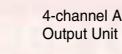
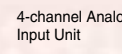
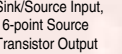
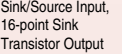
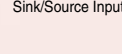

FN-X32TS41

FN-XY16SK41

FN-XY16SC41

FN-AD04AH11*1

FN-DA04AH11*1

FN-HC10SK41

FN-PC10SK41

Teaching Loader FN-PC10LD41

EASY SCREEN CREATION & LOGIC PROGRAM DEVELOPMENT

Screen Editor and Logic Program Development Software

GP-PRO/PBIII - C-Package 03

GPPRO-CNT01W-P03

The GP-PRO/PBIII C-Package combines screen creation and logic programming capabilities into one handy package. Using the simple "settings navigator," even beginners can create easy-to-use operating environments.



EASY SCREEN CREATION

Time Scheduling

This function makes it easier to set up devices and handle routine tasks.

Bit On/Off and word setting can be scheduled by day of the week or for a specific time. The weekly and time setting can also be changed on the display device.



Security Level Function

Restrict user access depending by operator level.

Use the 15-level password protection function to restrict access to specific screens, such as management and maintenance screens. This protection function helps to improve screen security, which also means greater safety for machines that are unattended or installed off-site.



Improved Keypad Display Function

We expanded the setting parameter display function for more efficient on-screen input.

- Touch input for input mode activation.
- A sequence designation function for inputting multiple items (with the group function).
- Designation of the change notification bit for individual setting parameter displays.
- A more flexible arrangement for the popup keyboard.



Text Screen's Multi-language Function

The text screen now supports multiple languages. A and X tags can be used to display different languages.



Improved Editing

Expanded Alarm Summary Display Function Using Q Tags

LOGIC PROGRAM

Supports Ladder Monitor

Current values and set values can be changed from the display screen.

Additionally, because the current values/set values can be altered not only from the ladder monitor but also the display screen, the contact point's ON/OFF and timer/counter's tuning can be performed even if a computer is not available.



Add New Instructions

15 kinds of ladder instructions, such as arithmetic functions, have been added. This makes developing programs much easier.

*Supported by GLC2000 series only (except for GLC2400/2600's old revisions.)

Command Extensions	Type
SUM	Sum (Returns total value of input array)
AVE	Average (Returns average value of input array)
RCL	Left Rotation with Carry
RCR	Right Rotation with Carry
SAL	Arithmetic Shift Left
SAR	Arithmetic Shift Right
BCNT	Bit Count
ASIN	Arc Sine
ACOS	Arc Cosine
ATAN	Arc Tangent
COT	Cotangent
EXP	Exponent e(x)->y
LN	Natural Logarithm Loge(x)->y
DEG	Degree Conversion (Radians ->Degrees)
SQRT	Square Root
RAD	Radian Conversion (Degrees ->Radians)

More Convenient to Operate

Inserted commands and variables are graphically displayed, making ladder programming mistakes easy to avoid.

OMRON

Series Name	CPU	Link	Direct	1:n	Multi-Link	Device-Net	Ethernet
SYSMAC CS1	CS1H-CPU64	●	●		●	●	●
	CS1H-CPU65	●	●		●	●	●
	CS1H-CPU66	●	●		●	●	●
	CS1H-CPU67	●	●		●	●	●
	CS1G-CPU42H	●	●		●	●	●
	CS1G-CPU43H	●	●		●	●	●
	CS1G-CPU44H	●	●		●	●	●
	CS1G-CPU45H	●	●		●	●	●
	CS1H-CPU63H	●	●		●	●	●
	CS1H-CPU64H	●	●		●	●	●
SYSMAC CJ	CJ1G-CPU44	●	●		●	●	●
	CJ1G-CPU45	●	●		●	●	●
	CJ1G-CPU42H	●	●		●	●	●
	CJ1G-CPU43H	●	●		●	●	●
	CJ1G-CPU44H	●	●		●	●	●
	CJ1G-CPU45H	●	●		●	●	●
	CJ1M-CPU12	●	●		●	●	●
	CJ1M-CPU13	●	●		●	●	●
	CJ1M-CPU22	●	●		●	●	●
	CJ1M-CPU23	●	●		●	●	●

ORIMVEXTA

Series Name	CPU	Link
E1	CPU11	●

Rockwell (Allen-Bradley)

Series Name	CPU	Link	Direct	Multi-Link	Device-Net	DH-485	DH-485 Remote I/O	Ethernet
SLC500	SLC-5/01	●						
	SLC-5/02	●						
	SLC-5/03	●						
	SLC-5/04	●						
	SLC-5/05	●						
PLC-5	PLC-5 Series	●						●
	PLC-5/11	●	●					
	PLC-5/20	●						
	PLC-5/30	●						
	PLC-5/40	●						
	PLC-5/40L	●						
Control Logix 5000	PLC-5/60	●						
	PLC-5/60L	●						
	1756-L1	●						
	1756-L1M1	●						
	1756-L1M2	●						
	1756-L1M3	●						
	1756-L55M13	●						
	1756-L55M14	●						
	1756-L55M16	●						
	1761-L16AWA	●						
MicroLogix1000	1761-L32AWA	●						
	1761-L20AWA-5A	●						
	1761-L10BWA	●						
	1761-L16BWA	●						
	1761-L20BWA-5A	●						
	1761-L32BWA	●						
	1761-L10BWB	●						
	1761-L16BWB	●						
	1761-L20BWB-5A	●						
	1761-L32BWB	●						
MicroLogix1200	1761-L16BBB	●						
	1761-L32BBB	●						
	1761-L32AAA	●						
	1762-L24AWA	●						
	1762-L24BWA	●						
	1762-L24BWB	●						
	1762-L40AWA	●						
	1762-L40BWA	●						
	1762-L40BWB	●						
	1762-L40BWB-5A	●						
MicroLogix1500	1764-LSP	●						
	1764-LRP	●						
CompactLogix	1769-L35E	●						

Schneider Electric

Series Name	CPU	Modbus RTU	Modbus TCP	Uni-Telway
Nano	TSX 07 30 10□□	●		●
	TSX 07 31 16□□	●		●
	TSX 07 31 24□□	●		●
	TSX 07 32 □□28	●		●
	TSX 07 33 □□28	●		●
	TSX 07 3L □□28	●		●
	TSX 07 05 028DR1	●		●
	TSX 07 08 056DR1	●		●
	TSX 07 10 128DR1	●		●
	TSX 07 10 128DR1	●		●
Micro	TSX 07 10 128DR1	●		●
	TSX 07 10 164DR1	●		●
	TSX 07 10 164DR1	●		●
	TSX 07 10 028AR1	●		●
	TSX 07 10 028DR1	●		●
	TSX 07 21 101	●		●
	TSX 07 22 101	●		●
	TSX 07 21 001	●		●
	TSX 07 22 001	●		●

Schneider Electric

Series Name	CPU	Modbus RTU	Modbus TCP	Uni-Telway
Premium	TSX P57 103M	●	●	●
	TSX P57 153M	●	●	●
	TSX P57 203M	●	●	●
	TSX P57 253M	●	●	●
	TSX P57 303M	●	●	●
	TSX P57 353M	●	●	●
	TSX P57 453M	●	●	●
	TWD LCAA 10DRF	●		
	TWD LCAA 16DRF	●		
	TWD LCAA 24DRF	●		
Twido	TWD LMDA 20DRF	●		
	TWD LMDA 20DUK	●		
	TWD LMDA 20DRF	●		
	TWD LMDA 40DTK	●		
	TWD LMDA 40DUK	●		
	TWD LMDA 113 02	●		
	140 CPU 113 03	●		
	140 CPU 413 12A	●		
	140 CPU 543 14A	●		
	171 CCS 700 10	●		
Quantum	171 CCS 700 10	●		
	171 CCS 780 00	●		
	171 CCC 780 10	●		
	171 CCS 780 00	●		
	171 CCC 960 2030	●		
	171 CCC 960 2030	●		

Sharp

Series Name	CPU	Link	Multi-Link
New Satellite JW	JW20	●	
	JW-32CUH	●	
	JW-32CUH1	●	
	JW-33CUH3	●	●
	JW50	●	
	JW70	●	
JW100	●		

Shinko Electric

Series Name	CPU	Link
SELMART	SELMART	●

SIEMENS

Series Name	CPU	Link	Direct	Profibus	MPI	INTERBUS	Ethernet
SIMATIC-S5	S5 90U	●	●				
	S5 95U	●	●				
	S5 100U	●	●				
	S5 115U	●	●				
	S5 135U	●	●				
	S5 155U	●	●				
	CPU212	●					
	CPU214	●					
	CPU215	●					
	CPU216	●					
SIMATIC-S7 200	CPU312IFM	●					
	CPU313	●					
	CPU314	●					
	CPU314IFM	●					
	CPU315	●					
	CPU315-2DP	●					
	CPU316	●					
	CPU316-2DP	●					
	CPU318-2	●					
	CPU412-1	●					
SIMATIC-S7 400	CPU412-2DP	●					
	CPU413-1	●					
	CPU413-2DP	●					
	CPU414-1	●					
	CPU414-2DP	●					
	CPU414-3DP	●					
	CPU416-1	●					
	CPU416-2DP	●					
	CPU416-3DP	●					
	CPU417-4	●					
SIMATIC 505	SIMATIC545-1101	●					
	SIMATIC545-1102	●					
	SIMATIC545-1103	●					
	SIMATIC545-1104	●					
	SIMATIC545-1105	●					
	SIMATIC545-1106	●					
	SIMATIC555-1101	●					
	SIMATIC555-1102	●					
	SIMATIC555-1103	●					
	SIMATIC555-1104	●					

Toshiba

Series Name	CPU	Link	Multi-Link	Ethernet
PROSEC EX	EX2000	●		
PROSEC T	T3	●	●	
	T3H	●		●

Toshiba

Series Name	CPU	Link	Multi-Link	1:n
PROSEC T	T2N	●		●
	T2E	●		
	B200CH	●		
PROVISOR B	B200CUF	●		
	B200CURM	●		
	B200CUFRM	●		
	S2PU22A	●	●	
V Series	S2PU32A	●	●	
	S2PU72A	●	●	●
	S2PU72D	●	●	●
	S3PU45A	●	●	●
	S3PU55A	●	●	●
	S3PU65A	●	●	●

Toshiba Machine

Series Name	CPU	Link
PROVISOR TC800	TCCUH	●
	TCCUHS	●
	TCCUSS	●

Toyoda Machine Works

Series Name	CPU	Link	1:n
TOYOPUC-PC2	PC2	●	
	L2	●	
	PC2J	●	●
TOYOPUC-PC3	PC3J	●	●

Yaskawa Electric

Series Name	CPU	Link	Direct	Multi-Link	Ethernet
Memocon-SC	U84	●			
	U84J	●			
	U84S	●			
	GL40S	●			
	GL60S	●			
	GL60H	●			
	GL70H	●			
	GL120	●	●		
	GL130	●	●	●	
	CP-9200	●			
Control Pack	CP-9200H	●			
	CP-9200SH	●			
	Micro	●			
Memocon Micro	PROGIC-8	●			
	MP900	●			●
	MP930	●			
MP2000	MP2300	●			●

Yokogawa

Series Name	CPU	Link	Direct	1:n	Multi-Link	n:m	Ethernet	Device-Net
FACTORY ACE	FA500	●	●	●	●	●	●	●
	FA-M3	●	●	●	●	●	●	●
STARDOM	FCN	●						
	FCJ	●						

Ubon

Series Name	CPU	Link
UPZ		

GLC Distributed I/O System

FLEX NETWORK I/O SPECIFICATIONS

		DIO Terminals									
		8-point I/O		16-point I/O			32-point I/O		64-point I/O		
		8-point Relay Output/ 1 Common	16-point Sink/Source Input	8-point Sink/Source Input, 8-point Sink Transistor Output	16-point Sink Output	16-point Source Output	32-point Sink/Source Input	16-point Sink/Source Input, 16-point Sink Transistor Output	32-point Sink/Source Input, 32-point Transistor Sink Output		
		Model	FN-Y08RL41	FN-X16TS41	FN-XY08TS41	FN-Y16SK41	FN-Y16SC41	FN-X32TS41	FN-XY16SK41	FN-XY16SC41	FN-XY32SKS41
Electrical	Rated Voltage	DC24V									
	Allowable Voltage Range	DC20.4V to DC28.8V									
	Allowable Voltage Drop	10ms or less (for DC24V power supply)									
	Internal Power Consumption	1.0W or less	1.5W or less			2.5W or less		3.5W or less			
Environmental	Voltage Endurance	AC1500V at 10mA for 1 minute (between power/Input and Output, and FG terminals.)									
	Insulation Resistance	10MΩ or higher at DC500V (between power/Input and Output, and FG terminals.)									
	In-rush Current	30A or less									
	Operating Temperature	0°C to +55°C									
Structural	Storage Temperature	-25°C to +70°C									
	Operating Humidity	5% RH to 95% RH (non-condensing, wet bulb temperature: less than 39°C)									
	Storage Humidity	5% RH to 95% RH (non-condensing, wet bulb temperature: less than 39°C)									
	Air Purity (Dust)	0.1mg/m ³ or less (non-conductive levels)									
	Pollution Degree	Pollution degree 2									
	Corrosive Gas	Free of corrosive gases									
	Vibration Endurance	5Hz to 55Hz, 60m/s ² for 2 hours each in X, Y, and Z directions				IEC61131-2 (JIS B 3501) compliant When vibration is NOT continuous: 10Hz to 57Hz 0.075mm, 57Hz to 150Hz 9.8m/s ² When vibration is continuous: 10Hz to 57Hz 0.035mm, 57Hz to 150Hz 4.9m/s ² X, Y, Z directions for 10 times (80min.)					
	Shock Endurance	300m/s ² (for 10ms in X, Y, and Z directions-3 times each)				IEC61131-2 (JIS B3501) Compliant 147m/s ² (for 11ms in X, Y, Z directions-2 times each)					
	Noise Immunity (via noise simulator)	Noise voltage: 1000Vp-p, Pulse Duration: 1μs, Arise time: 1ns									
	Electrostatic Discharge Immunity	Contact Discharge Method 6kV (IEC 61000-4-2, Level 3)									
Input/Output	Attachment Method	via 35mm DIN rail or by attachment screws									
	Cooling Method	Natural air circulation									
	Weight	150g or less				350g or less					
Input	External Dimensions	W108mm [4.25in] x H45mm [1.77in] x D49mm [1.93in]				W110mm [4.33in] x H95mm [3.74in] x D57mm [2.24in]		W135mm [5.31in] x H95mm [3.74in] x D46mm [1.81in]			
	Rating	IP20									
	Rated Input Voltage	DC24V		DC24V		DC24V		DC24V			
	Max. Input Voltage	DC28.8V		DC28.8V		DC28.8V		DC28.8V			
	Input Points	16 points (common for sink/source types)		8 points (common for sink/source types)		32 points (common for sink/source types-dual use)		32 points (common for sink/source types-dual use)			
	Input Type	Type 1 ¹		Type 1 ¹		Type 1 ¹		Type 1 ¹			
	Input ON Voltage	DC15V or more		DC15V or more		DC15V or more		DC15V or more			
	Input OFF Voltage	DC5V or less		DC5V or less		DC5V or less		DC5V or less			
	Input Impedance	4.1kΩ		4.1kΩ		4.2kΩ		4.2kΩ			
	Input Delay	OFF - ON	1.5ms or less		1.5ms or less		1.5ms or less		1.5ms or less		
Output	Rated Output Voltage	DC24V		DC24V		DC24V		DC24V			
	Output Terminal Allowable Voltage Range	DC20.4V to DC28.8V		DC20.4V to DC28.8V		DC20.4V to DC28.8V		DC20.4V to DC28.8V			
	Power Consumption	1.2W or less (when all outputs are ON/DC24V)		—		—		—			
	Output Points	8 points/1 common		8 points (open drain sink output)		16 points (open drain sink output)		16 points (open drain source output)			
	Max. Load Current	1.0A/point (8 points/1 common, max. common current 4.0A)		0.2A/point (8 points/1 common, max. common current 1.6A)		0.2A/point (16 points/1 common, max. common current 2.0A)		0.2A/point (16 points/1 common, max. common current 1.6A)			
	Short-circuit Protection	—		None		None		None			
	Built-in Fuse	—		—		3.5A, DC125V built-in Chip Fuse (cannot be replaced)		—			
	Voltage Drop (ON Voltage)	—		DC1.5V or less		DC1.5V or less		DC1.5V or less			
	Clamp Voltage	—		DC39V±1V		DC39V±1V		DC39V±1V			
	Current Leakage	—		0.1mA or less		0.1mA		0.1mA or less			
Output Delay Time	OFF - ON	10ms or less		5ms or less		1ms or less		1ms or less			
ON - OFF	5ms or less		—		1ms or less		1ms or less				
Contact Rating	1A at AC240V (resistive load, dielectric load) 1A at DC24V (resistive load, dielectric load)		—		—		—				
Max. Closing Load	1mA/DC5V		—		—		—				
Initial Contact Resistance	50mΩ or less		—		—		—				
Electrical Lifetime	100,000 operations or more		—		—		—				
Mechanical Lifetime	20,000,000 operations or more		—		—		—				
Number of Occupied Nodes	1		2		1		4				

¹ When connecting units to the Flex Network, use Flex Network communication cables for stable, high-speed communications.

International Safety Standards

Model numbers ending in "41" comply with the following standards:

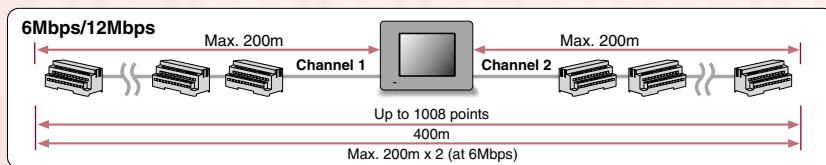

		Single-axis Positioning Unit	High-speed Counter Unit	Analog Units		
		High-spec Units			4-channel Analog Input Unit	4-channel Analog Output Unit
		Model	FN-PC10SK41/Teaching Loader: FN-PC10LD41	FN-HC10SK41	FN-AD04AH11	FN-DA04AH11
Electrical	Rated Voltage	DC24V				
	Allowable Voltage Range	DC20.4V to DC28.8V				
	Allowable Voltage Drop	10ms or less (for DC24V power supply)				
	Internal Power Consumption	4.5W or less	2.5W or less		4.8W or less	7.2W or less
Environmental	In-rush Current	30A or less		30A or less		
	Voltage Endurance	AC500V 20mA for 1 min. (combined I/O power and FG terminals)		AC500V 20mA for 1 min. (between I/O and earth terminals)		
	Insulation Resistance	10MΩ or higher at DC500V (combined I/O power and FG terminals)		10MΩ or higher at DC500V (between I/O and earth terminals)		
	Operating Temperature	0°C to +55°C		0°C to +55°C		
Structural	Storage Temperature	-25°C to +70°C		-25°C to +70°C		
	Operating Humidity	30% RH to 95% RH (non-condensing)		30% RH to 95% RH (non-condensing)		
	Storage Humidity	30% RH to 95% RH (non-condensing)		30% RH to 95% RH (non-condensing)		
	Air Purity (Dust)	0.1mg/m ³ or less (non-conductive levels)		0.1mg/m ³ or less (non-conductive levels)		
	Corrosive Gas	Free of corrosive gases		Free of corrosive gases		
	Atmospheric Pressure	800hPa to 1,114 hPa (2,000m or lower)		800hPa to 1,114 hPa (2,000m or lower)		
	Vibration Endurance	IEC61131-2 (JIS B 3501) compliant When vibration is NOT continuous: 10Hz to 57Hz 0.075mm, 57Hz to 150Hz 9.8m/s ² When vibration is continuous: 10Hz to 57Hz 0.035mm, 57Hz to 150Hz 4.9m/s ² X, Y, Z directions for 10 times (80min.)		IEC61131-2 (JIS B 3501) compliant When vibration is NOT continuous: 10Hz to 57Hz 0.075mm, 57Hz to 150Hz 9.8m/s ² When vibration is continuous: 10Hz to 57Hz 0.035mm, 57Hz to 150Hz 4.9m/s ² X, Y, Z directions for 10 times (80min.)		
	Shock Endurance	IEC61131-2 (JIS B3501) Compliant 147m/s ² (for 11ms in X, Y, Z directions-2 times each)		IEC61131-2 (JIS B3501) Compliant 147m/s ² (for 11ms in X, Y, Z directions-2 times each)		
	Noise Immunity (via noise simulator)	Noise voltage: 1000Vp-p, Pulse Duration: 1μs, Arise time: 1ns		Noise voltage: 1000Vp-p, Pulse Duration: 1μs, Arise time: 1ns		
	Electrostatic Discharge Immunity	Contact Discharge Method 6kV (IEC 61000-4-2 Level 3)		Contact Discharge Method 6kV (IEC 61000-4-2 Level 3)		
Attachment Method	Attachment Method	via 35mm DIN rail or by attachment screws				
	Cooling Method	Natural air circulation				
	Weight	700g [1.54lb] or less (Main unit only)		150g [0.33lb] or less		
External Dimensions	External Dimensions	W122mm [4.80in] x H196mm [7.72in] x D35mm [1.38in]		W108mm [4.25in] x H49mm [1.93in] x D45mm [1.77in]		
	Rating	IP30 (without terminal block)		IP20		
	No. of Control Axis	1		1		
Performance	Input Control	Photo-coupler Isolation		Photo-coupler Isolation		
	Program Method	Sequence program, Teaching loader		Sequence program, Teaching loader		
	Max. Positioning Memory	90 points (ABS/INC)		90 points (ABS/INC)		
	Pulse Output Method	CW/CCW Line Driver Output/Open Collector Output		CW/CCW Line Driver Output/Open Collector Output		
	Output Frequencies *2	1.5625pps to 62.5kpps/6.25pps to 250kpps/12.5pps to 500kpps/50pps to 2Mpps (set via parameters)		1.5625pps to 62.5kpps/6.25pps to 250kpps/12.5pps to 500kpps/50pps to 2Mpps (set via parameters)		
	Max. Pulse Output	+/-2,147,483,647 pulses		+/-2,147,483,647 pulses		
	Accelerate/Decelerate Method	Trapezoidal and Sinusoidal curves		Trapezoidal and Sinusoidal curves		
	Position Settings	Absolute/Incremental		Absolute/Incremental		
	Backlash Correction	0 to 65,535 pulses		0 to 65,535 pulses		
	Control Mode	Manual, Automatic, Direct		Manual, Automatic, Direct		
Origin Point Return	4 Types (option, low-speed, 2 types of high speed)		4 Types (option, low-speed, 2 types of high speed)			
Origin Point Correction	-32,767 to 32,767 pulses		-32,767 to 32,767 pulses			
Control Input	Rated Input Voltage	DC24V		DC24V		
	Maximum Allowable Input Voltage	DC26.4V		DC26.4V		
	No. of Input Points	5 points (1 common)		5 points (1 common)		
	Input ON Voltage	DC19V or higher		DC19V or higher		
	Input OFF Voltage	DC5V or less		DC5V or less		
	Input Impedance	3.9kΩ		3.9kΩ		
	Input Delay	OFF-ON	1.5ms or less		1.5ms or less	
	ON-OFF	1.5ms or less		1.5ms or less		
	Communication Configuration	1: N		1: N		
	Connection Method	Multi-Drop Connection		Multi-Drop Connection		
Maximum Distance	200m/channel at 6Mbps; 100m/channel at 12Mbps		200m/channel at 6Mbps; 100m/channel at 12Mbps			
Communication Method	Cycle Time Division, half-duplex		Cycle Time Division, half-duplex			
Communication Speed	6Mbps, 12Mbps		6Mbps, 12Mbps			
Communication Interface	Differential, pulse-transformer isolation		Differential, pulse-transformer isolation			
Error Check	Format, bit, CRC-12 verification		Format, bit, CRC-12 verification			
Z Phase Input	Rated Input Voltage	DC5V		DC5V		
	Maximum Allowable Input Voltage	DC5.5V		DC5.5V		
	No. of Input Points	1		1		
	Input Impedance	330Ω		330Ω		
	Input ON Voltage	DC4V or higher		DC4V or higher		
	Input OFF Voltage	DC1V or lower		DC1V or lower		
	Input Delay	OFF-ON	1.5ms or less		1.5ms or less	
	ON-OFF	1.5ms or less		1.5ms or less		
	Rated Output Voltage	DC24V		DC24V		
	Maximum Allowable Output Voltage	DC24V (+/-10%)		DC24V (+/-10%)		
No. of Output Points	1		1			
Maximum Load Current	50mA or less		50mA or less			
Output Hold Feature	None		None			
Voltage Drop (ON Voltage)	DC1.5V or less		DC1.5V or less			
Clamp Voltage	DC39V +/-1V		DC39V +/-1V			
Current Leakage	0.1mA or less		0.1mA or less			
Output Delay Time	OFF-ON	1ms or less		1ms or less		
ON-OFF	1ms or less		1ms or less			
Rated Output Voltage	DC5V		DC5V			
Maximum Allowable Output Voltage	DC4.5V to DC5.5V		DC4.5V to DC5.5V			
No. of Output Points	2 points (CW/CCW)		2 points (CW/CCW)			
Maximum Load Current	50mA or less		50mA or less			
Output Hold Feature	None		None			
Voltage Drop (ON Voltage)	DC0.8V or less		DC0.8V or less			
Differential Output	Equivalent to TI Corp. SN75158		Equivalent to TI Corp. SN75158			
Output Hold Feature	None		None			
Number of Occupied Nodes	4		4			
Open Collector	Rated Output Voltage	DC24V		DC24V		
	Rated Output Voltage Range	DC24V (+/-10%)		DC24V (+/-10%)		
	Output Voltage Drop	DC1.5V or lower		DC1.5V or lower		
	Output Current	50mA or lower		50mA or lower		
	Output Delay	OFF-ON	Maximum: 1ms		Maximum: 1ms	
	ON-OFF	Maximum: 1ms		Maximum: 1ms		
	Leakage Current	0.1mA or lower		0.1mA or lower		
	Rated Input Voltage	DC5V		DC5V		
	Max. Input Voltage	DC4.5V to DC5.5V		DC4.5V to DC5.5V		
	Calculated Speed (Rise and Fall Time)	t _r = 0.5μs or less (200kpps)		t _r = 10μs or less (10kpps)		
Min. Pulse Width	2.5μs		50μs			
Input Signal Phase	90° phase differential 2-phase signal, 1 phase + directional signal, 1 phase addition signal		90° phase differential 2-phase signal, 1 phase + directional signal, 1 phase addition signal			
Input Impedance	470Ω		4.9kΩ			
Input ON Voltage	DC19V or higher		DC19V or higher			
Input OFF Voltage	DC5V or lower		DC5V or lower			
Input Delay	OFF-ON	Maximum: 1.5ms		Maximum: 1.5ms		
ON-OFF	Maximum: 1.5ms		Maximum: 1.5ms			
Rated Output Voltage	DC24V		DC24V			
Rated Output Voltage Range	DC24V (+/-10%)		DC24V (+/-10%)			
Output Voltage Drop	DC1.5V or lower		DC1.5V or lower			
Output Current	50mA or lower		50mA or lower			
Output Delay	OFF-ON	Maximum: 1ms		Maximum: 1ms		
ON-OFF	Maximum: 1ms		Maximum: 1ms			
Leakage Current	0.1mA or lower		0.1mA or lower			

¹ Digital input is for detecting signals from mechanical switching devices such as relay contacts, push buttons, switches, etc.

² Max. speed for open collector output is 100kpps.

³ FN-AD04AH11 is an impedance 1kΩ. FN-DA04AH11 is an impedance 1kΩ.

⁴ FN-AD04AH11 is an impedance 200Ω. FN-DA04AH11 is an impedance 400Ω.

⁵ Between input terminal and internal circuit (FN-AD04AH11).

Between output terminal and internal circuit (FN-DA04AH11).

GLC Distributed I/O System

FLEX NETWORK I/O CIRCUIT DIAGRAMS

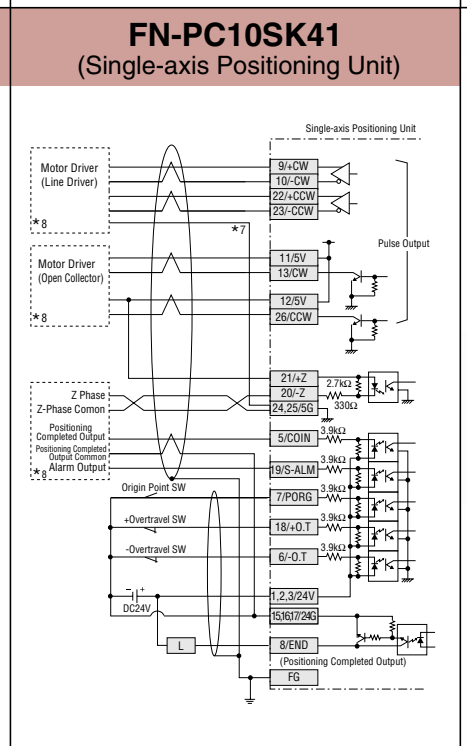
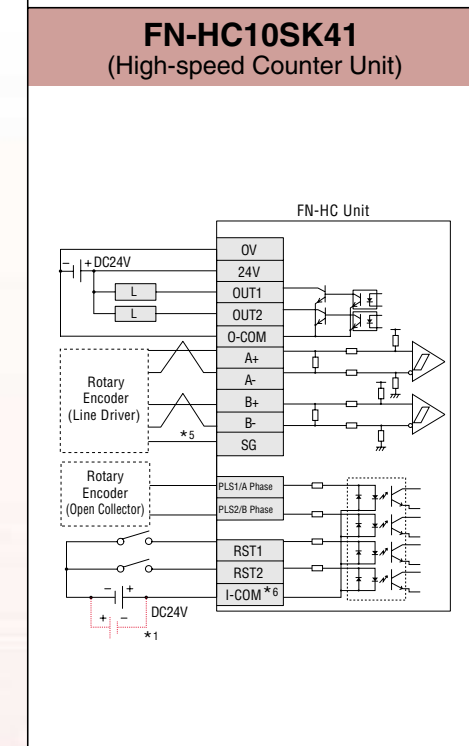
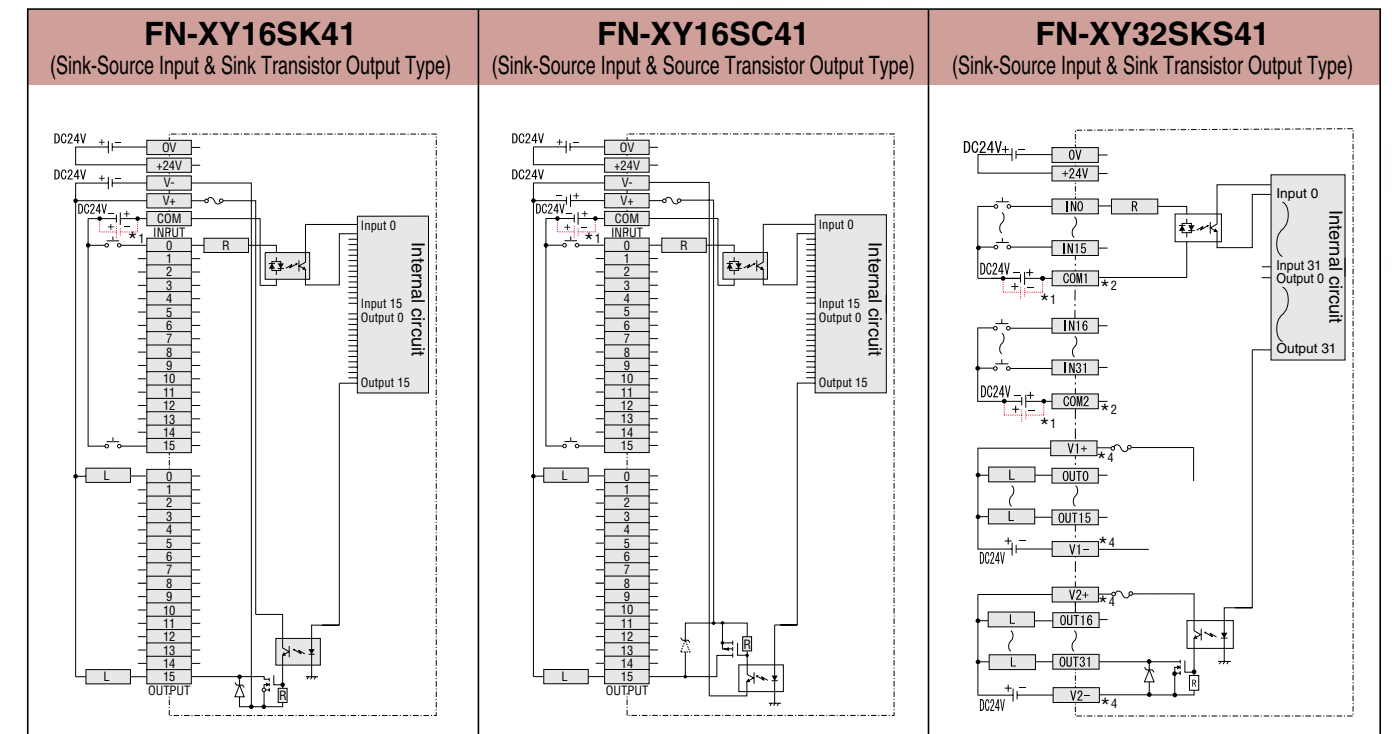
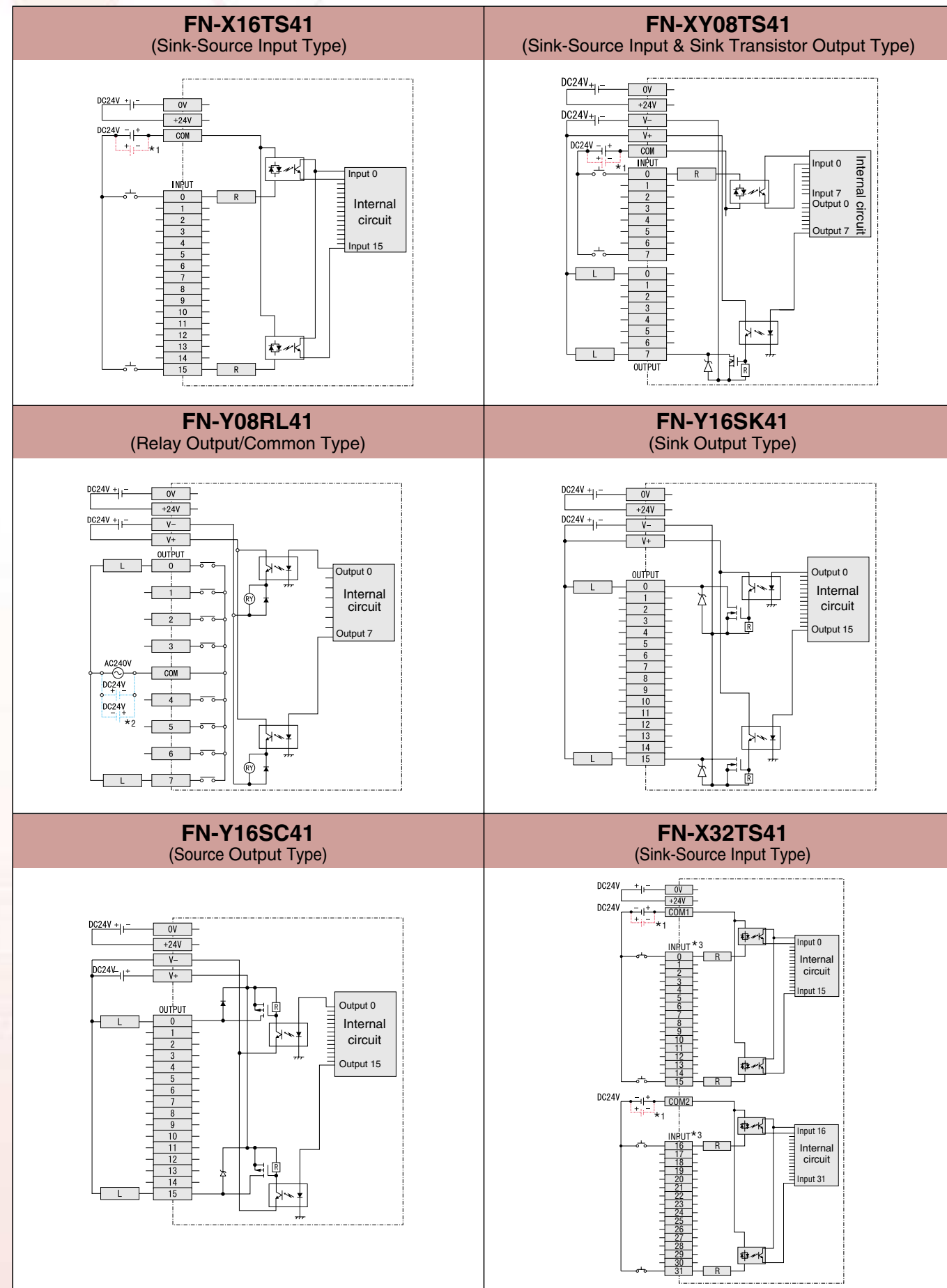

- *1 Dotted line shows the source output connection.
- *2 The COM power supply can be changed according to the relay specifications.
- *3 When using IN0 to IN15, use COM1. When using IN16 to IN31, use COM2 as the input common.
- *4 For OUT0 to OUT15, connect the output power to V1+/V1-. For OUT16 to OUT31, connect the output power to V2+/V2-.
- *5 The FN-HC unit's input line is not isolated. When connecting this unit to a non-isolated line driver, be sure to connect the signal ground (SG terminal).
- *6 The Input Common (I-COM) shown here is connected to a Sink Output type. (The dotted line shows the connection with a Source Output type.)
- *7 The FN-PC unit's live line is not isolated. If it is connected to a non-isolated servo driver, be sure to connect the signal ground (5G) to prevent an over-current accident.
- *8 For motor driver connection details, refer to appendix 1.

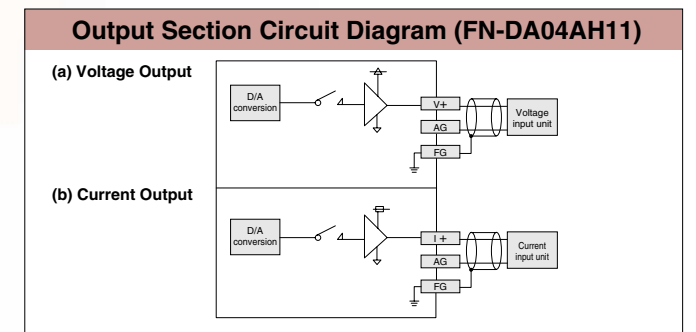
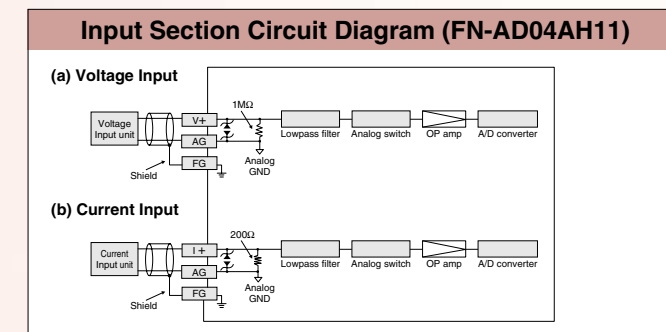

Specifications

GLC DISTRIBUTED I/O (FLEX NETWORK) I/F SPECIFICATIONS

Communication Type	1:N
Connection Method	Multi-Drop Connection
Transfer Distance	6Mbps 200m per CH, at 12Mbps 100m per CH
Transfer Method	During cyclic period, distributed transmission, Half-duplex
Transfer Speed	6Mbps, 12Mbps
Transfer I/F	Differential method, Pulse transfer resistance
Error Check	Format, bit, CRC-12 verification
No. of Nodes	63 (max.), 1008 I/O points

I/F Connector (GLC2600T/2500T/2400T)

Pin No.	Signal Name	Condition		Pin Assignments
1	AUXCOM	External Reset Common	Ext.Reset	
2	AUXRESET	External Reset Input		
3	TR+	CH1 Communication Data	Flex Network	
4	TR-	CH1 Communication Data		
5	SLD	CH1 Cable Shield Line		
6	TR+	CH2 Communication Data		
7	TR-	CH2 Communication Data		
8	SLD	CH2 Cable Shield Line		
9	RESERVE	Reserved	Sound Output	
10	SP OUT	Speaker Output		
11	GND	Ground		
12	LINE OUT	Sound Lineout Output		

I/F Connector (GLC2300T/L)

Pin No.	Signal Name	Condition		Pin Assignments
1	TR+	CH1 Communication Data		
2	TR-	CH1 Communication Data		
3	SLD	CH1 Cable Shield Line		
4	TR+	CH2 Communication Data		
5	TR-	CH2 Communication Data		
6	SLD	CH2 Cable Shield Line		

SERIAL I/F (COM1) SPECIFICATIONS

Recommended Connector: Dsub 25-pin plug XM2A-2501 (OMRON)
Recommended Cover: Dsub 25-pin cover XM2S-2511 (OMRON)
 Jack Screws XM2Z-0071 (OMRON)
 * Use rough metric type M2.6x0.45 p threads to secure the cable's set screws.
Recommended Cable: CO-MA-VV-SB5P 28AWG (Hitachi Cable Ltd.)

Serial I/F	Asynchronous: RS-232C/RS-422, Data length: 7 or 8bits; Stop bit: 1 or 2bits; Parity: none, odd or even; Data transmission speed: 2400 to 115.2kbps (MPI: 187.5kbps)
------------	--

SIO Connector Specifications

Pin No.	Signal Name	Condition	Pin Assignments
1	FG	Frame Ground	
2	SD	Send Data (RS-232C)	
3	RD	Receive Data (RS-232C)	
4	RS	Request Send (RS-232C)	
5	CS	Clear Send (RS-232C)	
6	DR	Data Set Ready (RS-232C)	
7	SG	Signal Ground	
8	CD	Carrier Detect (RS-232C)	
9	TRMX	Termination (RS-422)	
10	RDA	Receive Data A (RS-422)	
11	SDA	Send Data A (RS-422)	
12*	NC	No Connection (Reserved)	
13*	NC	No Connection (Reserved)	
14	VCC	5V ±5% Output 0.25A	
15	SDB	Send Data B (RS-422)	
16	RDB	Receive Data B (RS-422)	
17	RI	Ring Indicate (RS-232C)	
18	CSB	Clear Send B (RS-422)	
19	ERB	Enable Receive B (RS-422)	
20	ER	Enable Receive (RS-232C)	
21	CSA	Clear Send A (RS-422)	
22	ERA	Enable Receive A (RS-422)	
23*	NC*	No Connection (Reserved)	
24*	NC*	No Connection (Reserved)	
25*	NC*	No Connection (Reserved)	

*Pins 12, 13, 23, 24 and 25 are reserves. Do not connect anything to them.

COMMON I/F SPECIFICATIONS

Tool Connector

Tool Connector	Asynchronous: TTL level non-procedural command Connect data transfer cable for transferring data, serial printer, Bar code reader
----------------	---

SERIAL I/F (COM2) SPECIFICATIONS

Recommended Connector: Dsub 9-pin socket XM2D-0901 (OMRON)
Recommended Cover: Dsub 9-pin cover XM2S-0913 (OMRON)
 Jack Screws XM2Z-0073 (OMRON)

SIO Connector Specifications

Pin No.	Signal Name	Signal Direction	Condition	Pin Assignments
1	CD	Input	Carrier Detect (RS-232C)	
2	RD	Input	Receive Data (RS-232C)	
3	SD	Output	Send Data (RS-232C)	
4	ER	Output	Enable Receive (RS-232C)	
5	SG	—	Signal Ground	
6	DR	Input	Data Set Ready (RS-232C)	
7	RS	Output	Request Send (RS-232C)	
8	CS	Input	Clear Send (RS-232C)	
9	RI/VCC	Input/Output	Ring Indicate (RS-232C) +5V+5% 0.25A	

PRINTER INTERFACE SPECIFICATIONS

Pin No.	Signal Name	Condition	Pin Assignments
1	GND	Ground	
2	RESERVE	Reserved	
3	PDB5	Data Signal	
4	PDB4	Data Signal	
5	PDB3	Data Signal	
6	GND	Ground	
7	SLCT	Select Status (Input)	
8	PDB0	Data Signal	
9	PSTB	Strobe Signal (Output)	
10	BUSY	Busy Signal (Input)	
11	PDB7	Data Signal	
12	PDB6	Data Signal	
13	GND	Ground	
14	ERROR	Printer Error (Input)	
15	GND	Ground	
16	PDB2	Data Signal	
17	PDB1	Data Signal	
18	PE	Paper Runout	
19	INIT	Initialization Signal (Output)	
20	GND	Ground	

Accessories

SOFTWARE

Screen Editor and Logic Program Development Software
GP-PRO/PB III
 Package
 GPPRO-CNT01W-P**

Data Collection Software
Pro-Server
 with Pro-Studio
 PSW-ED01-V**

Pro-Server Add-on Software
GP-Viewer
 PSW-GV01-V**

Web Operation Software
GP-Web
 GW-CJ01-V**

FOR TOOL CONNECTOR

Data Transfer Cable
GPW-CB02

USB Data Transfer Cable
GPW-CB03

FOR CF CARD INTERFACE

CF Card (64MB)
CA3-CFCALL/64MB-01
 CF Card (128MB)
CA3-CFCALL/128MB-01
 CF Card (256MB)
CA3-CFCALL/256MB-01
 CF Card (512MB)
CA3-CFCALL/512MB-01

CF Card Adaptor
GP077-CFAD10
 CF Card Front Maintenance Unit*
GP077-CFFM10 For GLC 2600T For GLC 2500T

* This Unit cannot be used at the same time as the Bus Conversion Unit (PSL-CONV00)

FOR SERIAL INTERFACE (COM1)

RS-232C Cable (5m)
GP410-IS00-O

RS-422 Cable (5m)
GP230-IS11-O

For Multi-link Cable
GP230-IS12-O

RS-442 Connector Terminal Block Adaptor
GP070-CN10-O

CPU I/F Cable for Mitsubishi PLC A, QnA Series
GP430-IP10-O

CPU I/F Cable for Mitsubishi PLC FX Series
GP2000-CBLFX/1M-01
GP2000-CBLFX/5M-01

FOR EXPANSION UNIT INTERFACE 1

Two-port Adapter II for Mitsubishi PLC A, QnA, FX Series
GP070-MD11

FOR EXPANSION UNIT INTERFACE 2

PROFIBUS Slave Unit *1
CA1-PFSALL-21 CE

DeviceNet Slave Unit *1
CA1-DNSALL-21 CE

CANopen Slave Unit *1
CA1-COSALL-21 CE

Video-mix Unit
GP2000-VM41 CE

*1 To be sold at only Pro-Face Europe B.V.. For further information, please contact Pro-face Europe B.V..

FOR PRINTER INTERFACE

Printer Cable (2m)
PSM-PRCB00 For GLC 2600T For GLC 2500T For GLC 2400T

FOR FLEX NETWORK

Flex Network Communication Cable
FN-CABLE 2010-31-MS (10m)
FN-CABLE 2050-31-MS (50m)
FN-CABLE 2200-31-MS (200m)

Motor Driver Connection Cable
FN-PC10CB01 (1m)

64-point I/O unit DIO Connector (Spring Type)
GLC-DIOCN03

Single-axis Teaching Loader Cable
FN-LD10CBL (5m)

Screw Lock Terminal Block
GLC2300-FNCN01 For GLC 2300L/T

FOR MAINTENANCE OPTION

Backlight
PS600-BU00 For GLC 2600T

Rubber Gasket
GP570-WP10-MS For GLC 2600T For GLC 2500T

Installation Fastener
GP070-AT01

Screen Protection Sheet (5 sheets/set)
PSL-DF00 For GLC 2600T For GLC 2500T

Connector Cover
GP577RT-BL00-MS For GLC 2500T

PS400-WP00-MS For GLC 2400T

Screw Lock Terminal Block
GPM-AXCN01 For GLC 2600T For GLC 2500T For GLC 2400T

PS400-DF00 For GLC 2400T

PS400-BU00-MS For GLC 2400T

PS300-WP00 For GLC 2300L/T

PS300-DF00 For GLC 2300L/T

Smooth system integration of Pro-face products is assured with a total support network.

WORLDWIDE SUPPORT



Pro-face regional offices and partners offer technical support and repair services around the world. Contact your local Pro-face office for more information about support services available.

ACCESS!!

www.pro-face.com

Worldwide Contacts:

General Info: info@pro-face.com
 Technical Info: support@proface.co.jp

Conformity with International Safety Standards

Pro-face products and component parts bearing the CE Mark and the UL or C-UL Listing and Recognized Component Marks are your guarantees of compliance with safety standards accepted in countries and regions worldwide.



Caution: Before operating any of these products, please be sure to read all related manuals thoroughly.

- For printing purposes, the colors in this catalog may differ from those of the actual unit.
- Actual user screens may differ from the screens shown here.
- LCD screens may exhibit minute grid-points (light and dark) on the Display Panel surface. Also, "Contouring" - where some parts of the screen are brighter than others, producing a wavelike pattern - may occasionally occur. Both are normal for an LCD display and are not defects.

- Microsoft® Excel, Access are registered trademarks of Microsoft Corporation.
- All product names used in this catalog are the registered trademarks of their respective companies.
- All information contained in this catalog is subject to change without notice.

©2004 Digital Electronics Corporation All Rights Reserved.

Global Head Office

Digital Electronics Corporation
 8-2-52 Nanko-higashi
 Suminoe-ku, Osaka 559-0031
 JAPAN
 Tel: +81-(0)6-6613-3116
 Fax: +81-(0)6-6613-5888
<http://www.pro-face.com>
info@pro-face.com

Asia Pacific Regional Office

Digital Electronics Corporation
 Bangkok Representative Office
 2034/52 (11-07/4), 11th floor
 Italthai Tower,
 New Phetchburi Road
 Bangkok, Huaykwang,
 Bangkok 10320
 THAILAND
 Tel: +66-(0)2-716-1733
 Fax: +66-(0)2-716-1737

Scandinavia

Pro-face Scandinavia ApS
 Copenhagen Vallensbækvej 18A
 DK-2605 Brøndby
 DENMARK
 Tel: +45 70 22 01 22
 Fax: +45 70 22 01 33
<http://www.pro-face.dk>
info@pro-face.dk

Italy

Pro-face Italia S.p.a.
 Via G. di Vittorio 26
 20030 Bovisio Masciago (Milano)
 ITALY
 Tel: +39 0362 59 96 1
 Fax: +39 0362 59 96
<http://www.pro-face.it>
info.italia@proface.it

China

Wuxi Pro-face Electronics Co., Ltd.
 Shanghai Office
 Room 2001, Singluar Mansion
 No.322, Xian Xia Road
 Shanghai 200336
 P. R. CHINA
 Tel: +86-(0)21-6208-6367
 Fax: +86-(0)21-6208-4816
<http://www.proface.com.cn>
proface@proface.com.cn

North/South American Head Office

Pro-face America, Inc. / Xycorn
 750 North Maple Road
 Saline, MI 48176-1292
 U.S.A.
 Tel: +1-734-429-4971
 Fax: +1-734-429-1010
<http://www.profaceamerica.com>
sales.info@profaceamerica.com

Sweden

Pro-face Sweden AB
 Malmö Amiralsgatan 20
 SE-211 55 Malmö
 SWEDEN
 Tel: +46 (0)40 660 19 55
 Fax: +46 (0)40 660 19 40
<http://www.pro-face.dk>
info@pro-face.dk

United Kingdom

Pro-face UK Ltd
 Pro-face House 8 Orchard Court
 Binley Business Park Coventry CV3 2TQ
 ENGLAND
 Tel: +44 (0)2476 440088
 Fax: +44 (0)2476 440099
<http://www.profaceuk.com>
info@profaceuk.com

South Korea

Pro-face Korea Co., Ltd.
 4th floor, Cheil Bldg. 94-46
 Youngdeungpo-Dong 7Ka,
 Youngdeungpo-Ku Seoul 150-037
 SOUTH KOREA
 Tel: +82-(0)2-2630-9850
 Fax: +82-(0)2-2630-9860
 Support Center (A/S Center)
 Tel: +82-(0)31-940-3713
 Fax: +82-(0)31-940-3780
<http://www.proface.co.kr>
proface@proface.co.kr

European Head Office

Pro-face Europe B.V.
 Jadelaan 34-36 2132 XW Hoofddorp
 THE NETHERLANDS
 Tel: +31 (0)23 55 44 099
 Fax: +31 (0)23 55 44 090
<http://www.proface.com>
info@proface.com

Germany

Pro-face Deutschland GmbH
 Albertus-Magnus-Straße 11
 42719 Solingen
 GERMANY
 Tel: +49 (0)212 258 260
 Fax: +49 (0)212 258 2640
<http://www.pro-face.de>
sales@pro-face.de

Spain and Portugal

Pro-face España
 Apartado de Correos No 62
 E-08440 Cardedeu Barcelona
 SPAIN
 Tel: +34 (0)93 846 07 45
 Fax: +34 (0)93 845 48 68
<http://www.pro-face.es>
central@pro-face.es

Taiwan

Pro-face Taiwan Co., Ltd.
 4F, No. 77, Section 3, Nanjing East Road
 Taipei 104
 TAIWAN R.O.C.
 Tel: +886-(0)2-2507-1102
 Fax: +886-(0)2-2507-1104
<http://www.proface.com.tw>
proface@proface.com.tw

France

Pro-face France S.A.S.
 Le Vinci 7
 1, rue Henri Becquerel
 77290 Mitry-Mory
 FRANCE
 Tel: +33 (0)1 60 21 22 91
 Fax: +33 (0)1 60 21 22 92
<http://www.proface.fr>
info@proface.fr

Switzerland

Pro-face Deutschland GmbH
 Niederlassung Schweiz
 Krummbuckweg 6
 8157 Dielsdorf
 SWITZERLAND
 Tel: +41 (0)1 8853322
 Fax: +41 (0)1 8853330
<http://www.pro-face.ch>
info@pro-face.ch

NP040522-GLC2000-05E15